

**BUSINESS PLAN  
Q4/2001**

**A Billion Dollar Opportunity:**  
Using a new & powerful  
Wireless Messaging Protocol  
to capture the  
Wireless Application Service Provider  
market

**LEAP: An Alternative to WAP**

**Neda Communications, Inc.**

3610 164th Place SE  
Bellevue, Washington 98008  
Phone: (425) 644-8026  
Fax: (425) 644-2886  
Website: <http://www.neda.com>

Version 4.4

October 24, 2001

This document does not constitute an offer to sell, or a solicitation of an offer to purchase.

# Contents

<b>1</b>	<b>Executive Summary</b>	<b>1</b>
1.1	The Opportunity . . . . .	1
1.2	WAP: A Fraudulent Solution . . . . .	2
1.3	LEAP: A Genuine Solution . . . . .	2
1.4	Our Business Model: A Dichotomy . . . . .	3
1.5	Making LEAP Widespread (First Half of Business Model) . . . . .	3
1.5.1	LEAP: A Truly Open & Free Protocol . . . . .	4
1.5.2	Open-Source Software Implementations . . . . .	4
1.5.3	Free Subscriber Services . . . . .	4
1.5.4	The LEAP Manifesto: The Whole Story in Writing . . . . .	4
1.5.5	Result: Success of LEAP . . . . .	5
1.5.6	All Assets Complete and Ready To Go . . . . .	5
1.5.7	Marketing Opportunity . . . . .	6
1.6	Operation WhiteBerry: The Strategic Spearhead . . . . .	6
1.7	Profiting from LEAP (Second Half of Business Model) . . . . .	6
1.7.1	All Assets Complete and Ready To Go . . . . .	7
1.8	The Company . . . . .	7
1.9	The Team . . . . .	8
1.10	Maximizing Profits . . . . .	8
1.10.1	Broad-Based Subscriber Services . . . . .	9
1.11	Schedule, Financing, Use of Proceeds, and Exit . . . . .	9
<b>2</b>	<b>About This Document</b>	<b>11</b>
2.1	The LEAP Manifesto . . . . .	11
2.2	Reading Road Map . . . . .	13
2.3	Other Document Formats . . . . .	13
<b>3</b>	<b>The LEAP Protocols</b>	<b>13</b>
3.1	The Need for Efficiency . . . . .	14
3.2	Technical Overview of LEAP . . . . .	14
3.2.1	The ESRO Layer: Efficient Transport Services . . . . .	14
3.2.2	The EMSD Layer: Efficient E-Mail . . . . .	16
3.2.3	The EHTD Layer: Efficient Web Browsing . . . . .	16
3.2.4	Other Efficient LEAP Applications . . . . .	16
3.3	Efficiency Characteristics of LEAP . . . . .	16

3.4	LEAP: A Basis for Convergence	18
3.5	The End-User's Experience	18
3.6	The LEAP Development Process	21
3.6.1	Patent-Freedom	22
3.6.2	RFC Publication	22
3.6.3	Open Maintenance Organizations	22
3.7	LEAPing over WAP	22
3.8	A Brief History of LEAP	22
<b>4</b>	<b>The Opportunity</b>	<b>23</b>
4.1	Scope: Building an Entire Industry	23
4.2	The Time is Ripe	23
4.3	An Attack on WAP	24
4.4	Hype versus Reality	24
<b>5</b>	<b>Business Model and Strategy</b>	<b>26</b>
5.1	Nomenclature: Free Software and Open-Source Software	26
5.2	The Open-Source Software Puzzle	26
5.3	The Supply Chain Model	27
5.4	Business Model: A Dichotomy	28
5.5	Business Model: Highly Unconventional	28
5.5.1	Separation of Interests	31
5.6	An Industry-Building Blueprint	31
<b>6</b>	<b>The Company</b>	<b>32</b>
6.1	Incorporation History	32
6.2	Operational History	32
6.3	Company Mission	33
6.4	Company Values	33
6.5	Technology Balance Sheet	34
6.5.1	Marketing Agreements	34
6.6	Recent Licensees	34
6.7	Recent Client List	35
6.8	Relationship with the Free Protocols Foundation	35
6.9	The Team	36
6.10	Outside Support	36
<b>7</b>	<b>Strategic &amp; Financing Options</b>	<b>37</b>

7.1	Mobile Messaging Market Segments . . . . .	37
7.2	Three Strategic Options . . . . .	37
7.2.1	Strategy I: The Protocol-Based Strategy . . . . .	38
7.2.2	Strategy II: The Product-Based Strategy . . . . .	38
7.2.3	Strategy III: The Subscriber Services Strategy . . . . .	39
7.3	Neda's Choice: The Subscriber Services Strategy . . . . .	39
7.3.1	Timing . . . . .	39
7.3.2	Financing Options . . . . .	40
7.4	The Target Investor . . . . .	40
7.4.1	Investor Conflict of Interest . . . . .	41
<b>8</b>	<b>Phase I: Making LEAP Widespread</b>	<b>41</b>
8.1	Key Ideas for Growth of LEAP . . . . .	41
8.2	Three Virtual Business Units from the Start . . . . .	42
8.3	LEAP Protocols Business Unit . . . . .	42
8.3.1	Protocol Development and Promotion . . . . .	43
8.3.2	Neda's Software Base . . . . .	43
8.3.3	Neda's Software Licensing Strategy . . . . .	44
8.3.4	Neda's Software Distribution Strategy . . . . .	45
8.3.5	LEAP Protocol Engines Software Packages . . . . .	45
8.3.6	Consulting Services . . . . .	46
8.4	LEAP Products Business Unit . . . . .	46
8.4.1	Message Center & Network Products . . . . .	47
8.4.2	Device Products . . . . .	49
8.5	Subscriber Services Business Unit . . . . .	51
8.6	Phase I Marketing Plan . . . . .	51
8.7	Phase I Goals . . . . .	52
8.8	Operation WhiteBerry . . . . .	52
8.9	Phase I Financing . . . . .	53
<b>9</b>	<b>Phase II: Capturing the Subscriber Services Business</b>	<b>54</b>
9.1	Three Business Units from the Beginning . . . . .	54
9.1.1	The LEAP Protocols Business Unit . . . . .	54
9.1.2	The LEAP Products Business Unit . . . . .	54
9.1.3	The Subscriber Services Business Unit . . . . .	55
9.2	Neda's Subscriber Services Model . . . . .	55
9.2.1	Subscriber Services Up Front . . . . .	56

9.2.2	Characteristics of Neda’s Subscriber Services . . . . .	56
9.2.3	Initial Subscriber Services: ByName.net & ByNumber.net . . . . .	58
9.3	Why Will We Succeed? . . . . .	60
9.4	The Need for Financing . . . . .	62
9.5	Phase II Use of Proceeds . . . . .	62
9.5.1	Recruitment . . . . .	62
9.6	Risks and Competition . . . . .	63
9.6.1	Non-Risk: Competing Protocols . . . . .	63
9.6.2	Non-Risk: Competing Software . . . . .	63
9.6.3	Slight Risk: Shortsightedness of the Phone Companies . . . . .	64
9.6.4	Major Risk: Inability to Execute . . . . .	64
9.6.5	Major Risk: Competing Subscriber Services . . . . .	64
9.6.6	Major Risk: Timing . . . . .	65
9.7	Financial Projections . . . . .	66
9.7.1	Full Funding Financial Projections . . . . .	66
9.7.2	No Funding Financial Projections . . . . .	68
<b>10</b>	<b>The Way Forward</b> . . . . .	<b>68</b>
10.1	A Challenge to the Investor . . . . .	68
10.2	Distinguishing Between Hype and Substance . . . . .	70
10.3	Knowing Your Values . . . . .	70
<b>A</b>	<b>Neda Team Biographies</b> . . . . .	<b>78</b>
A.1	Principals . . . . .	78
A.1.1	Mohsen Banan, President, Neda Communications, Inc. . . . .	78
A.1.2	Pean Lim, Principal Engineer . . . . .	78
A.1.3	John Urrutia, CFO, Neda Communications, Inc. . . . .	79
A.1.4	Andrew Hammoude, Consultant . . . . .	79
A.2	Advisors . . . . .	80
A.2.1	Joseph J. Pruskowski, Advisor . . . . .	80
A.2.2	Murat Divringi, Advisor . . . . .	80
A.3	Associates . . . . .	81
A.3.1	Mark McWiggins, Associate . . . . .	81
A.4	Technical Staff . . . . .	81
A.4.1	Pinneke Tjandana, Technical Staff, Neda Communications, Inc. . . . .	81
A.4.2	Arghavan Banan, Technical Staff, Neda Communications, Inc. . . . .	82

<b>B Partners &amp; Outside Support</b>	<b>82</b>
B.1 Van Valkenberg Furber Law Group P.L.L.C.	82
B.2 Perkins Coie	82
B.3 Public Relations Companies	82
B.4 Sun Micro Catalyst Program	82
<b>C Neda Technology Balance Sheet</b>	<b>83</b>
C.1 Protocol Specifications	83
C.2 Publications	83
C.3 Neda Products	84
C.3.1 Neda Product Summary	84
C.3.2 ETWP-User Agent Products	85
C.3.3 ETWP-Server-Agent Products	86
C.3.4 EMSD Protocol Technology Products	87
C.3.5 ESRO Protocol Technology Products	88
C.4 Neda Subscriber Services	89
C.5 Networks and Domains	90
C.6 Infrastructure, Tools and Procedures	90
<b>D Recent Licensees</b>	<b>90</b>
<b>E Recent Client List</b>	<b>92</b>
<b>F Trying Out LEAP</b>	<b>93</b>

## List of Figures

1 LEAP Protocol Organization	15
2 Protocol Efficiency Comparison	17
3 Open Mobile Messaging	19
4 The End-User's Experience	20
5 Wireless Internet Hype vs. Reality	25
6 Traditional Supply Chain Model	29
7 Protocol Success Stories	72
8 Protocol-Based Industry Building Blueprint	73
9 Neda Software Architecture	74
10 Neda's Licensing Strategy	75
11 Neda's Subscriber Services at a Glance	76

12	Full Funding Financial Projections . . . . .	77
13	Neda's Domains & Networks . . . . .	91

## List of Tables

1	WAP versus LEAP . . . . .	23
2	Three Strategic Options . . . . .	38
3	Message Center Market Subsegments . . . . .	48
4	LEAP Device Software Products . . . . .	50

## Preface

Neda is not a conventional company, and this is not a conventional business plan.

One of the most counterintuitive aspects of our business model is its very high degree of openness. The foundations of our business model consist of a set of wireless messaging protocols called LEAP, and a comprehensive suite of software implementations of those protocols. The protocols and their software implementations were developed by Neda over a period of several years, and therefore represent a major investment of company resources. The protocols and software are key assets, around which everything else in our business model turns.

Yet despite this, we are giving these assets away. We are giving away the protocols by making them patent-free and freely available, and we are giving away the software implementations by making them available as open-source.

The general openness of our model also extends to our written Business Plan. There is no great need for secrecy with regard to the plan; on the contrary, it is very much in our interest for there to be widespread awareness and discussion of our business model. For this reason we are subjecting the Business Plan to wide distribution and readership.

This does not mean that the Business Plan is a public document. It remains a confidential document, for which Neda remains the sole source of distribution, and which may not be copied or redistributed by anyone else. But this is not because there is any real need for secrecy; rather, it is for two other practical reasons. First, there are strict legal restrictions on the distribution of a business plan, and an investment opportunity like Neda cannot reasonably be directed towards the public at large, but should only be directed towards qualified investors. Second, although the readership will be broad, we wish to select that readership ourselves, and limit it to investors and partners of our choosing. Therefore, as recipient of this Business Plan, you are required to respect fully the confidentiality statement on the cover page. However, if you feel that the plan would be of interest to another party, please let us know; if appropriate, we will then gladly provide them with a copy.

Our philosophy and methodology for presenting our Business Plan to investors differs from the customary practice. We view the writing and distribution of the Business Plan as one element in the creation of a general framework for general industry participation. Other elements of this framework consist of the publication of the LEAP protocols as Internet RFCs, the creation of public forums for enhancement and maintenance of the protocols, the distribution of open-source software implementations of the protocols, and the publication of *The LEAP Manifesto*.

We have created an enormous profit-making opportunity. Together, the above elements provide a complete framework for participation by others – including but not limited to the investment community.

Based on this philosophy we are subjecting our plan to broad distribution, and we consider it the responsibility of the recipient investors to determine whether they wish to participate or not. Therefore in most cases we will not be following up on our distribution of the plan to you. If you would like to participate at this early stage, we invite you to contact us.

Regardless of whatever else you may think of this plan, we hope you will find it interesting reading.



# 1 Executive Summary

In less than a decade the use of e-mail and wireless devices has grown spectacularly. These two technologies are now about to give rise to a third: the combination of e-mail and wireless technology, or **Mobile Messaging**.

Neda Communications, Inc. intends to play a leadership role in the creation of an entirely new industry based on this technology: the open Mobile Messaging industry. We have designed a set of protocols for Mobile Messaging called the **Lightweight & Efficient Application Protocols**, or **LEAP**. These protocols will become the industry standard as a result of two powerful forces: (i) the protocols are open and patent-free, and (ii) they will be distributed as Open-Source Software.

Several Mobile Messaging products and services have already been developed, but in all cases these are based on protocols which are closed, or at best pseudo-open. A good example is the BlackBerry messaging system from Research in Motion (RIM), which is based on entirely closed and proprietary protocols. Meanwhile, a crude attempt to launch the messaging industry on the basis of a set of protocols has been made in the form of an entirely inadequate set of specifications called the Wireless Application Protocol, or WAP. The tremendous amount of hyperbole, controversy, and dissatisfaction surrounding WAP is a clear indication of the industry's need and readiness for the right set of protocols. As the basis for creation of the Mobile Messaging industry, LEAP is superior to non-open solutions such as BlackBerry and WAP in every respect.

The success of the LEAP protocols will catalyze enormous industry growth. Neda's name recognition and first mover advantage will place it in prime position to capitalize on this growth.

This business plan is about an industry-building opportunity. Initially Neda will generate revenue from multiple segments of this expanding industry. In the long term, however, the major, strategic revenue-generating opportunity is the Subscriber Services business. Neda will position itself to target this segment of the industry as the industry matures.

Since 1994 Neda has been actively developing all the assets required to create this new industry and profit from its growth. All these assets are now complete, and we are ready to execute our plans immediately. This business plan includes no vaporware.

## 1.1 The Opportunity

Rudimentary forms of mobile messaging technology exist already; several products and services are available which provide end-users with basic messaging capability. However, major development of the Mobile Messaging industry is currently being blocked by the lack of an adequate industry-standard messaging protocol. The adoption by the industry of a standard protocol will cause this logjam to be broken, resulting in enormous industry growth.

The business opportunities represented by this are gigantic, as has been made abundantly clear by numerous market forecasts providing growth projections for wireless devices, services and networks. For an industry overview, including some sample data, see the article *The Mobile Messaging Industry* [?].

By virtue of our leadership role in their development and distribution, the success of the LEAP protocols will create incomparable mindshare and name recognition for Neda Communications. At the outset, this mindshare will far exceed that enjoyed by any competing LEAP software solution provider. Initially, we will capitalize fully on this mindshare by generating software and services revenues from *every* relevant industry segment, including the message center software and systems market, the device software market, and the LEAP technology market. We will leave no significant profit-making opportunity unexploited.

Though they provide a major revenue source, software products do not represent the really big opportunity in the Mobile Messaging industry. The ultimate, truly spectacular opportunity in this arena consists of the Wireless Application Service Provider (WASP) market, and it is this market that represents Neda's business target in the long term.

The success of the LEAP protocols provides the key entry point for this, by placing Neda at the absolute dead center of the wireless application arena. In the short term, the resulting mindshare puts Neda first in line to profit from the wireless software market. And in the long term, this gives Neda a unique entry ticket into the Subscriber Services market. The company that leads the way by defining the industry standard is in a uniquely advantageous position to participate in, profit from, and potentially dominate, the WAP market. It is our intention to position Neda to profit fully from this market as the LEAP-based wireless industry comes to maturity.

This leadership/participation/domination role is both a major opportunity and a major challenge. This challenge need not be met by Neda acting alone – this could equally well be accomplished by an appropriate industry partnership in which Neda plays a central role.

## 1.2 WAP: A Fraudulent Solution

WAP is claimed by its proponents to be the solution to the industry's need for a unifying protocol, and is being aggressively marketed as such. In April 2000, however, we published our article entitled *The WAP Trap: An Exposé of the Wireless Application Protocol* [?], in which we state the truth of the matter. In that article we demonstrate that the WAP protocols are entirely unfit for their claimed purpose – they are the result of a closed design process, are tightly controlled by the WAP Forum, are crippled with patents, and are riddled with technical design errors. We concluded that WAP is a fraudulent marketing construct rather than a genuine engineering one.

Eighteen months after initial publication of *The WAP Trap*, our analysis and predictions have been convincingly validated, and WAP has been widely discredited within the wireless industry [?], [?]. At this point WAP is intensely disliked by developers, and is becoming increasingly so by the entire communications industry. Neda's solution is superior to WAP in every respect, and it will succeed where WAP will fail.

All of this provides Neda with a ready-made public relations opportunity. We intend to go publicly toe-to-toe with WAP, positioning our solution as an open, patent-free and viable alternative to WAP. As part of this positioning strategy we recently published a follow-on article to *The WAP Trap* entitled *WAP Scraps* [?]. In that article we point out how recent wireless protocol developments have now rendered WAP completely irrelevant, and we discuss whether anything useful can be salvaged from WAP.

## 1.3 LEAP: A Genuine Solution

The key component of Neda's plans is a set of mobile messaging protocols called **LEAP**. LEAP is a set of high-performance, efficient protocols which are ideal for mobile and wireless applications.

LEAP originated in 1994 as part of the research and development initiatives of McCaw Cellular's wireless data group (now AT&T Wireless Services). The development work that would eventually lead to LEAP was initially undertaken in the context of the CDPD (Cellular Digital Packet Data) network; its scope was later expanded to include the Narrowband PCS network also.

By 1996 McCaw Cellular was fully committed to paging, had recently purchased two nationwide narrowband wireless PCS licenses, and wished to develop an efficient wireless messaging system. Neda Communications, Inc., working under contract to McCaw Cellular, played a key role in the development of the required system.

In 1997 however, soon after the purchase of McCaw Cellular by AT&T Wireless, the latter company abandoned the wireless messaging project. Prior to this event, Neda had secured from AT&T the necessary rights to continue independent development of the protocols. Therefore, recognizing the eventual future need for these protocols, Neda then undertook to continue development of them independently of AT&T. They were eventually completed by Neda, published as RFCs [?] [?], and now form the basis of the LEAP protocols.

Prior to abandoning wireless messaging, AT&T Wireless Services invested several million dollars in related development work. In creating LEAP, therefore, Neda was able to build upon a large abandoned investment by AT&T Wireless.

Over the past five years, Neda has independently developed complete software implementations of the LEAP protocols for major device PDAs and message centers, so as to create a complete end-to-end messaging solution. All this software is now distributed by Neda as free, open-source software under the terms of the Gnu General Public License (GPL).

The LEAP protocols have been designed from the outset as a genuine enabling technology for the benefit of the industry and the consumer. They are a sound engineering construction based on true openness and patent-freedom.

Mobile applications demand both power and bandwidth efficiency, and existing Internet protocols do not provide this efficiency. LEAP is a mainstream native Internet protocol that is up to five times more efficient than the ubiquitous SMTP messaging protocols. LEAP is a general-purpose solution to the problem of efficient message transfer, and is not restricted to any particular device or network. In particular, LEAP is compatible with all wireless-IP networks. Examples of wireless networks which provide native support for LEAP are: CDPD, GSM, packet CDMA, and PCS.

The LEAP protocols are layered. The lower layer, called Efficient Short Remote Operations (ESRO), provides reliable connectionless transport services which can be used for a variety of applications. Built on top of ESRO is EMSD (Efficient Mail Submission & Delivery). EMSD is a messaging protocol that is highly optimized for the submission and delivery of short internet mail messages. Efficient Hyper Text Delivery (EHTD) is a hypertext transfer protocol which is optimized for transfer efficiency of short markup pages. EHTD is the member of the LEAP protocols which facilitates web browsing; it also benefits from the reliable efficient services of ESRO. A multiplicity of efficient markup languages can be used in conjunction with EHTD. Development of the EHTD protocol is in progress.

## **1.4 Our Business Model: A Dichotomy**

Our business model includes the answers to two fundamental questions:

1. How will we ensure that the LEAP protocols become the industry standard?
2. How will we profit from this?

The answers to these two questions are very different, and this represents the basic dichotomy of our business model.

The answer to the first question is that we will promote the adoption of our protocols by the completely open and free nature of the protocols themselves, and by the Open-Source Software (OSS) model. In the OSS model, adoption of a software system is encouraged by providing it in the form of patent-free, open-source software, at no cost to the user. Since the software is free, it has an enormous advantage over traditional for-profit commercial software. The OSS model has been proven to be an effective and powerful mechanism for promoting software usage.

The question that the OSS model leaves unanswered is: how does the originator of the OSS system profit from its success? It would seem that giving away free software is an unbeatable way of ensuring its market acceptance, but an extremely poor way of making money.

Neda's business plan represents the marriage of two things: (1) the use of the Open-Source Software model to catalyze the growth of an industry, and (2) an explicit business plan for profiting from this growth. Not only are these two things not traditionally thought of as going together, they are traditionally considered to be fundamentally incompatible. In this plan, however, we are setting forth a blueprint for combining these two things successfully.

## **1.5 Making LEAP Widespread (First Half of Business Model)**

The first half of our business model consists of a strategy to ensure that the LEAP protocols become the Mobile Messaging industry standard.

This half of our business model contains no profit motivation whatsoever. Instead, we are motivated by only a single consideration: to promote the widespread usage of LEAP throughout every segment of the Mobile Messaging industry. In a nutshell, we do this by making LEAP a good solution, making it a complete solution, then giving it away for free.

### **1.5.1 LEAP: A Truly Open & Free Protocol**

The first element of this strategy is that LEAP is an open and free protocol. The LEAP protocols are patent-free, so that any company, organization, or individual may implement and use the protocols without incurring licensing fees or any other financial obligation.

In addition to being patent-free, the LEAP protocols are truly open. They have been published as Internet RFCs, thus ensuring that they remain freely and permanently available. Furthermore, they are supported by public maintenance organizations, so that anyone may participate in their further enhancement and development.

All of this serves to ensure that there are no financial, administrative, or other hindrances to the free usage, implementation, and evolution of the protocols. Note that this is in very sharp contrast to WAP, which is hobbled by patent restrictions, not RFC published, and closely controlled by the WAP Forum.

### **1.5.2 Open-Source Software Implementations**

The next element of our strategy is that Neda has created software implementations of the LEAP protocols for a variety of devices and message-center platforms, and is making these available in the form of open-source software. Neda has created a complete and comprehensive set of LEAP-based Mobile Messaging software products, including message center software, protocol engines software, and device software for a variety of handheld devices.

These software products address the needs of all the major segments of the Mobile Messaging industry, and are ready for immediate deployment to ISPs and wireless data carriers, intranet messaging system operators, device manufacturers and systems integrators, and personal desktop messaging users. These products are available as open-source software, free of charge, to anyone who wishes to use them.

### **1.5.3 Free Subscriber Services**

The availability of open-source implementations of the LEAP protocols is still not sufficient to ensure their adoption. In addition, Neda must also solve the chicken-and-egg problem of encouraging implementation of the LEAP protocols in both message center systems *and* end-user devices, each of which requires implementation of LEAP in the other.

Therefore a further element of our strategy is that Neda will provide subscriber services to support the initial implementation of our protocols and software, and to assist in bootstrapping them into widespread usage.

Neda provides subscriber services which accommodate various methods of accessing and using mobile messaging services. All of these subscriber services are provided by Neda free of charge.

### **1.5.4 The LEAP Manifesto: The Whole Story in Writing**

The technological and software elements described above are supported by a comprehensive set of written assets. First and foremost among these is *The LEAP Manifesto* [?], a collection of over 20 individual articles which collectively describe every aspect of the LEAP protocols.

Our models for promoting and profiting from the LEAP protocols are different in many ways from conventional engineering and business models, and for this reason we have chosen to refer to our description of these models as a “manifesto.” This term is interpreted by many to carry a negative connotation – it may be considered to imply an

extreme or fanatical viewpoint. However, no such connotation should be inferred here. While the Manifesto may indeed be considered radical by many, it is entirely well-founded and logical.

*The LEAP Manifesto* and our other written assets provide the final, vital component of our strategy for making LEAP widespread. These assets include articles and other documentation tools for communicating our message to every relevant segment of the wireless industry, including the engineering community, the business community, our customers, strategic partners, the media, the academic community, and the investment community.

### 1.5.5 Result: Success of LEAP

All of this is a complete recipe for the success of the LEAP protocols. In summary, the LEAP protocols will become the Mobile Messaging industry standard because:

- There is a clear need for such protocols within the industry
- They correctly address the technical requirements of the industry
- There are no credible competing protocols
- They are patent-free and without usage restrictions
- Open-source software implementations of the protocols are freely available
- Free subscriber services are available to support initial deployment of the protocols
- A comprehensive set of written materials exists to communicate the LEAP message to every industry segment

For these reasons, we expect the LEAP protocols to take off like wildfire within the Mobile Messaging industry. A set of protocols which satisfy a desperate industry need, have no competition, are completely free, and are skillfully promoted, cannot help but succeed – it is in the nature of such a creation to propagate extremely rapidly.

The LEAP protocols will have a unifying and catalyzing effect on the Mobile Messaging industry. They will provide an open and fertile environment in which businesses can market competing products and services. The best products and services will succeed, to the ultimate benefit of the consumer. And the Mobile Messaging industry will grow.

### 1.5.6 All Assets Complete and Ready To Go

All the technological, software and documentation assets required to implement the first half of our business model are complete, in place, and ready to go. These assets consist of:

**The Protocols Themselves.** The protocols are well-designed, meet all the technical requirements of the industry, and are published as [RFC-2188](#) [?] and [RFC-2524](#) [?]. The complete text of these RFCs is available at:

<http://www.rfc-editor.org>

**Freedom from Patents.** The protocols are permanently patent-free, and have been declared as such to the [Free Protocols Foundation](#). For details see:

<http://www.FreeProtocols.org>

**Open Maintenance Organizations.** The protocols are maintained by open and public organizations at:

<http://www.esro.org>

<http://www.emsd.org>

<http://www.LeanForum.org>

**Open-Source Software Implementations.** Open-source implementations of the protocols are ready and available for all major platforms and end-user devices. For details see:

<http://www.MailMeAnywhere.org>

**Subscriber Services.** Free subscriber services are ready and available to support initial deployment of the protocols in end-user devices. For details see:

<http://www.ByName.net>; <http://www.my.ByName.net>  
<http://www.ByNumber.net>; <http://www.my.ByNumber.net>

**The LEAP Manifesto.** A comprehensive set of articles and other documentation exists to support rapid and aggressive promotion of the LEAP protocols. For details see:

<http://www.LeapForum.org/LEAP/Manifesto/roadMap/index.html>

Collectively, these assets represent a complete recipe for the success of the LEAP protocols. All the pieces of the puzzle are complete and in place, and there are no missing pieces. Prospective investors are encouraged to visit the above websites and verify for themselves that everything we have described is real and available *now*. This business plan includes no vaporware.

### 1.5.7 Marketing Opportunity

As a result of its aggressive promotion by the WAP Forum, WAP has now achieved widespread name recognition throughout the wireless industry. This has had two major effects. First, WAP has become strongly disliked among the technical community who understand its shortcomings; and second, the resulting controversy has drawn attention to the need for a viable alternative to WAP. We will take full advantage of this current industry climate to market LEAP as the viable alternative to WAP.

## 1.6 Operation WhiteBerry: The Strategic Spearhead

This Business Plan is about the creation of the open Mobile Messaging industry. Since the scope of the plan is so large, we tend to speak about this industry in very general, abstract terms.

However, a crucial step in the execution of our plan is the deployment of an actual, tangible LEAP-based Mobile Messaging solution. We have created such a solution; we call it the **WhiteBerry** solution. WhiteBerry is a truly open messaging solution that can be implemented immediately based entirely on existing open-source software implementations of the LEAP protocols, and other existing technologies. WhiteBerry thus represents an immediate, concrete embodiment of the open Mobile Messaging paradigm.

The WhiteBerry solution provides equivalent functionality to existing closed messaging solutions such as the BlackBerry system, and will therefore displace these closed solutions entirely. We refer to the implementation of the open WhiteBerry model as **Operation WhiteBerry**.

Operation WhiteBerry forms the strategic spearhead of our campaign to promote the LEAP protocols. Complete details of Operation WhiteBerry are provided in an article entitled, appropriately enough, *Operation WhiteBerry* [?].

## 1.7 Profiting from LEAP (Second Half of Business Model)

Neda will acquire priceless name recognition from the success of the LEAP protocols, and from its central role in the creation of the Mobile Messaging industry. Because of this unrivaled name recognition and our first-mover advantage, Neda will be uniquely positioned to profit from the growth of the industry.

The Mobile Messaging industry can be viewed as four distinct and independent markets, each of which will generate a revenue stream for Neda. These four market segments, and the corresponding revenue streams, are:

1. **LEAP Message Center Software and Systems.** Neda's revenue streams will consist of sales of message center software and systems licenses to (i) ISPs and Wireless Data Carriers; (ii) Intranet Messaging System Operators, and (iii) Personal Desktop Messaging Users. The operating systems which are initially supported include Sun Solaris, Linux, and Windows NT.
2. **LEAP Device Software.** Neda's revenue stream will consist of sales of LEAP technology licenses to manufacturers of end-user devices such as cell phones, wireless data modems, two-way pagers and PDAs. The general-purpose device operating systems which are initially supported include Windows CE, Palm OS, and EPOC. Cell phones are supported by means of readily portable software written in the C language.
3. **LEAP Protocol Engines Software.** Neda's revenue stream will consist primarily of sales of LEAP technology licenses to Systems Integrators.
4. **LEAP Subscriber Services.** Neda will gain revenue as a result of rapidly increasing returns from virtual community building, eyeball capture, and advertising.

The proportions of revenues deriving from each of these sources will shift radically as the industry matures. Initially, the majority of Neda's revenues will be provided by sales of software, systems and technology licenses; i.e. from items 1 - 3 above. Though we will provide support for Subscriber Services (item 4) from the beginning, we do not expect this to be a significant revenue source at the outset.

However, as the industry matures, support for Subscriber Services will emerge as the dominant revenue stream, and will eventually eclipse all others. The Subscriber Services segment of the industry represents the ultimate, major, profit-making opportunity for Neda.

### 1.7.1 All Assets Complete and Ready To Go

An initial basis for all the technological and software assets required to implement the second half of our business model are also complete, in place, and ready to go. These assets consist of:

**Subscriber Services.** An initial set of free subscriber services is ready and in place. This will form the foundation for our long-term subscriber services and virtual community building plans. For details see:

<http://www.ByName.net>; <http://www.my.ByName.net>  
<http://www.ByNumber.net>; <http://www.my.ByNumber.net>

**Supported & Commercial Software & Solutions.** Message center and device software is ready and available for a variety of platforms. For details see:

<http://www.neda.com>

## 1.8 The Company

Neda Communications, Inc. is a well-established company with a proven track record of technical proficiency and profitability. Neda was founded in 1991, and between 1991 and 1997 operated as a successful data communications consulting company, with an average income from 1993 to 1997 of over \$1 million annually. To date Neda has received no external financing.

Neda has been actively involved in the wireless data industry since 1992. From 1992 through 1994 Neda acted as the lead designer and primary architect of the Cellular Digital Packet Data (CDPD) System Specifications. From 1994

through early 1997, Neda designed and implemented much of AT&T Wireless Services mobile messaging prototype software and systems, for use over Narrowband PCS and CDPD wireless networks.

In 1997, Neda substantially curtailed its consulting activities, and since then has been actively developing the assets required to implement this business plan.

In 1999 Neda was re-incorporated as a new legal entity, appropriately structured to undergo external financing.

Despite the fact that we have made very little investment in sales and marketing activities, we have already sold a number of LEAP-related licenses. Our most recent licensees are: Xypoint Corporation, INETCO Systems, AT&T Wireless Services Messaging Division, and Sema Group UK.

## **1.9 The Team**

Neda has a core team of technical and management personnel with extensive experience in the wireless data communications field, and a track record of technical accomplishment and business success. Among the team there are relationships going back almost twenty years, reflecting a long history of productive cooperation. Every member of the team fully understands and is committed to the execution of this business plan.

The team is led by Mohsen Banan, who has been running Neda since 1991. Mohsen was the primary architect of the network structure of the CDPD specification; he is also the primary author of the LEAP RFCs and of the LEAP software implementations.

Other team members have a similarly high level of technical and business expertise. Complete biographical data for each team member is provided in Appendix A of this business plan.

## **1.10 Maximizing Profits**

All the assets required for the first half of our plan are complete and ready to go. No external financing is required for this part of our plan, and we expect to succeed in our goal of promoting the LEAP protocols as the industry standard with or without financing.

We also have the assets and ability to make partial execution of the second half of our plan. We have the personnel, technical expertise, and business experience necessary to capitalize immediately on the success of the LEAP protocols, and we have complete confidence in our ability to generate a highly profitable revenue stream on this basis. The propagation of LEAP and the resulting name recognition of Neda will present us with abundant opportunity – our success and revenues will be limited only by the limits of our ability to grow rapidly and take advantage of it.

Indeed, the opportunity is so large that it is far beyond our ability to take full advantage of it. In order to do this, we need external financing. With an appropriate level of external investment, the scale of our success can be multiplied many times over, resulting in a huge win for both Neda and her investors.

Neda is in the process of creating an enormous industry, with a correspondingly large profit-making opportunity. The ability of Neda to capitalize on this opportunity will be increased tremendously by means of a suitable level of investment. We are seeking funding to *increase dramatically the scale of our success*.

Initially, the majority of Neda's revenues will be generated by sales of software, systems and technology licenses. However, these revenue sources represent only a small fraction of the Mobile Messaging industry. It is the Subscriber Services segment of the industry that represents the truly gigantic, long-term, strategic opportunity. Neda is seeking funding in order to target this huge market.



### 1.10.1 Broad-Based Subscriber Services

The key to maximizing profits consists of aggressive pursuit of the Subscriber Services business. And the ultimate in profit maximization consists of the successful domination of this market. To achieve this goal, the necessary Subscriber Services must be appropriately structured. Among other things, they must have the following key characteristics:

- Free to users; supported by advertising and content providers
- Highly oriented towards urgent and important interpersonal messaging, in addition to traditional broad-based unified messaging capability
- Highly personalized buddy list, news, stocks, weather etc.
- For data devices: based on LEAP and mainstream Internet protocols
- For voice devices: speech recognition, text-to-speech, IVR
- A fully integrated virtual community for wired and wireless environments

A set of Subscriber Services structured along these lines allows its owner to develop a continuously increasing revenue stream based on virtual community building, data mining, eyeball capture, advertising revenues, and content provider charges.

The LEAP protocols provide Neda with a unique opportunity to do exactly that. We will take advantage of Neda's central role and spotlight position within the wireless industry as the basis for a comprehensive, sustained and credible campaign to claim the Subscriber Services market.

### 1.11 Schedule, Financing, Use of Proceeds, and Exit

The implementation of Neda's business plans consists of two very different phases of operation:

**Phase I** consists of the implementation of the first half of our business model, i.e. the active promotion of the LEAP protocols. Neda has begun implementing this phase already, and expects this to take approximately 9 months to complete.

**Phase II** refers to the phase of operations that follows the successful completion of Phase I. There are several shapes that this phase could take. One such shape would be the profit maximization strategy described above, i.e. an aggressive campaign to target the Subscriber Services market.

It can be seen that these two phases of operation are very different in nature. Phase I is extremely well characterized – the required assets, execution steps and schedule are all defined precisely. We know that Phase I can be fully accomplished on the basis of our existing assets and resources, requires very little financing, and can be self-financed as necessary. We are already executing this phase, will continue to do so, and expect to bring this phase to successful completion regardless of any external financing.

The expected state of affairs at the conclusion of Phase I is also very well characterized. At this point the LEAP protocols are in widespread use, the WhiteBerry model is widely implemented, Neda is generating a major revenue stream on the basis of software licenses, and the LEAP-based open Mobile Messaging industry is experiencing strong and rapid growth. But most important of all: *Neda is sitting at the epicenter of this growing industry, and is sitting there alone.*

It is this latter characteristic that is the key to Neda's enormous business opportunities in Phase II – and a principal reason for writing this Business Plan. Since Neda is occupying this unique position, there are many ways in which it

can profit from the rapid and early growth of the industry. At the smallest end of the opportunity spectrum, Neda can do no more than active development of the software licensing business. At the largest end, it can target the ultimate in profit maximization: domination of the WASP market. And anything in between.

A consequence of this abundance of opportunity is that Phase II cannot and should not be defined with precision at this point. Phase I can be characterized in concrete and deterministic terms: *execution of a plan to make LEAP widespread*. No such deterministic characterization can be made for Phase II. Rather, we think of it in general abstract terms: *contingent exploitation of available opportunity*.

If we assume that Neda will target the ultimate opportunity – domination of the Subscriber Services market – then Phase II would begin as Phase I reaches completion, with approximately 3 months of overlap with Phase I. Neda would require \$15 million in financing to implement this top-end strategy.

But Phase II is by nature very flexible in terms of scale and timing. It can consist of exploitation of any opportunity from the smallest up to the largest. Within broad limits, its implementation can be advanced or delayed. What this means is that the Phase II opportunity can accommodate a wide range of financing amounts and timing. The most profitable approach to this opportunity is to hit it as hard and fast as possible, and that means \$15 million, immediately. But the Phase II operations can be readily adapted to any amount and timing of financing. Therefore we are not allowing a specific definition of Phase II to dictate a specific amount of financing; rather the other way around. In other words, we will adapt the Phase II operations to amount of financing available, and the prevailing industry conditions at the time.

Therefore our formal financing solicitation statement as follows: **Neda is seeking up to \$15 million in financing, at any point over the next 12 months.**

This is an unconventional financing model, but it is the right one for this plan. To accommodate this model, we have put in place a well-defined, clearly structured and flexible framework for investment participation. This framework allows investors to participate to the extent and timing of their choosing.

Note that snapshots taken of Neda now, and at the conclusion of Phase I, will look very different. A snapshot today shows Neda with all the assets required to implement Phase I, and in the process of doing so. A snapshot taken at the end of Phase I will show the LEAP protocols in wide and increasing usage, Neda generating healthy and increasing software license revenues, and experiencing widespread and increasing name recognition. Clearly, investment at that time can no longer be characterized as “Early Stage,” and the opportunity to invest on those terms will no longer be available.

Investors who think of themselves as early stage participants should get involved now.

Financing proceeds will be used to:

- Expedite and accelerate Phase I operations
- Continue protocol development leadership
- Execute an aggressive and orchestrated promotion of LEAP in the wireless market
- Put in place a highly scalable business structure
- Execute contingent exploitation of the Phase II opportunities. In its most aggressive and ambitious incarnation, this will consist of major, long-term development of the Subscriber Services business

The complete business plan including detailed financial projections is available on request to serious investors and development partners.

All the development work necessary to execute our plans has been completed, and all the assets required for immediate and rapid implementation are fully in place. Also, our timing could hardly be better: the current technological climate is perfectly ripe for the introduction of the LEAP protocols; and a clumsy fake solution exists as a foil for our

genuine one. For these reasons we expect that execution of our plans will proceed extremely quickly, and investors will experience a large return on their investment within a very short timeframe.

Exit will be by means of any of the conventional mechanisms.

## 2 About This Document

Neda's business model consists of two radically different components. In very simple terms, the first component consists of a strategy for promoting a set of communications protocols as the Mobile Messaging industry standard, while the second component consists of a business plan for profiting from this.

These two components are sufficiently different in nature that they are described in two separate documents. The first component is described in a document called *The LEAP Manifesto* [?], while the second component is described in this document, the Neda Business Plan.

*The LEAP Manifesto* provides a complete description of what the LEAP protocols are, how and why they will succeed, and how they will catalyze the growth of the Mobile Messaging industry. The Neda Business Plan describes how we will profit from this growth. Together, these two documents provide a complete description of Neda's business model.

*The LEAP Manifesto* can be thought of as the public side of our business model, while this document can be thought of as the private side of our model. An understanding of *The LEAP Manifesto* is essential in order to understand this business plan. It is required reading for anyone who is considering investing in Neda.

### 2.1 The LEAP Manifesto

*The LEAP Manifesto* is organized as a series of largely independent articles. Each of these articles stands on its own, and can be read and understood independently of the others. Together, these articles provide a complete picture of the Mobile Messaging industry and the role of the LEAP protocols. *The LEAP Manifesto* consists of the following articles:

**Executive Summary.** An overview summary of the entire LEAP Manifesto.

#### Part I: The LEAP Protocols

**Overview of the LEAP Protocols.** A general overview description of the LEAP protocols.

**The LEAP Protocol Development Model.** A description of the processes used to develop the LEAP protocols, and how and why these differ from conventional development process. This article also includes a criticism of the IETF protocol development processes.

**Free Protocols Foundation Policies and Procedures.** A description of the Free Protocols Foundations processes to ensure the development and maintenance of patent-free protocols.

**ESRO: A Foundation for the Development of Efficient Protocols.** A technical description of ESRO, the transport mechanism component of LEAP.

**EMSD: The LEAP E-Mail Component.** A technical description of EMSD, the e-mail component of LEAP.

**Efficiency of EMSD.** A technical paper analyzing the efficiency characteristics of EMSD and comparing its efficiency to other e-mail protocols.

**A Brief History of LEAP.** A summary of the major events in the evolution of the LEAP protocols.

**The Future of LEAP.** A description of the planned future development of LEAP, including descriptions of several LEAP-based products and services which are currently under development.

## **Part II: LEAPing Over Closed Solutions**

**The WAP Trap.** A detailed criticism of a set of specifications called the Wireless Application Protocol, or WAP. This article demonstrates that WAP is entirely unfit to play the role of a Mobile Messaging industry standard.

**LEAP: One Alternative to WAP.** A point-by-point comparison of the LEAP protocols to the WAP specifications. This article demonstrates that LEAP has all the desirable characteristics of an industry standard protocol that WAP lacks.

**WAP Scraps.** A discussion of what can be salvaged from what remains of WAP.

**Operation WhiteBerry.** A description of how equivalent functionality to the closed BlackBerry mobile messaging solution can be implemented based on a completely open model, using existing open-source software implementations of LEAP, and existing off-the-shelf hardware components.

## **Part III: Making LEAP Widespread**

**Strategy for Making LEAP Widespread.** A description of our strategy for encouraging widespread usage of the LEAP protocols, including the distribution of open-source software implementations of the protocols, and the availability of free subscriber services.

**EMSD on Windows CE.** A technical paper describing the architecture and implementation of EMSD on Windows CE devices.

**LEAP on Palm OS.** A technical paper describing the architecture and implementation of LEAP on Palm OS devices.

**LEAP on Linux Based PDAs.** A technical paper describing the architecture and implementation of LEAP on Linux Based PDAs.

**Trying Out LEAP.** A step-by-step, hands-on demonstration of how the LEAP protocols can be used to turn any Windows CE device into a fully functional Mobile Messaging device.

**WhiteBerry and Bluetooth.** A description of how WhiteBerry and Bluetooth can be used in combination to bring new and enhanced messaging capabilities to the mobile professional.

**Use of EMSD for Mail Notification.** A description of how EMSD can be used to provide a general Mail Notification service.

**Lessons from History: Comparative Case Studies.** An analysis of the factors which lead to the success or failure of protocols, including discussions of several historical case studies.

## **Part IV: The Mobile Messaging Industry**

**The Mobile Messaging Industry.** An overview of the Mobile Messaging industry, and a description of the essential factors that are required for its long term success and growth.

## 2.2 Reading Road Map

Various other documents are available which provide further information about the LEAP protocols, Neda Communications, Inc., and our products and services.

If you just want to get a brief overview of what we are about, then of course the place to begin is with the Executive Summary in Section 1. In a few minutes reading this will give you a concise summary of all the major aspects of our business plans.

Following that, you may find it of interest to read the following three articles from *The LEAP Manifesto*:

- *The WAP Trap* [?]
- *LEAP: One Alternative to WAP* [?]
- *Operation WhiteBerry* [?]

These three documents describe the foundations of our business plans. *The WAP Trap* provides a critique of an existing set of communications specifications called WAP, and explains why they cannot succeed as an industry standard. *LEAP: One Alternative to WAP* provides a relatively brief introduction to the LEAP protocols, and compares them to WAP. *Operation WhiteBerry* describes how LEAP will form the basis for the open Mobile Messaging industry. These documents are fairly short, and all three can be read in an hour or so.

Depending on your reading style and your familiarity with the data communications industry, you may wish to continue to browse through other articles in *The LEAP Manifesto*, or you may prefer to jump straight into the Business Plan at this point. Various articles of *The LEAP Manifesto* provide essential support and justification for the Business Plan, so you may find it helpful to refer to those articles as you progress through the Business Plan. References to the appropriate manifesto articles are provided throughout the Business Plan.

When you have finished reading the Business Plan, you may find it worthwhile to page through Neda's Media Kit, and to visit the various websites referred to in the plan.

Following that, if you want to do further research and/or due diligence on Neda, then the references section of this Business Plan will direct you to a large amount of additional information. The references include pointers to the LEAP protocol specifications themselves, Neda product manuals and data sheets, and Neda subscriber services manuals. These various resources will demonstrate to you the ambitiousness and complexity of this venture, and our preparedness to undertake it.

## 2.3 Other Document Formats

This Business Plan is available in several alternative formats. In addition to printed form, it is also available electronically in plain text, PostScript, PDF, and HTML formats. In the HTML format, all references and URLs are "hot" and clickable, so this format is ideal for referential mode reading. Please feel free to request the format that best suits your needs.

We can also give a PowerPoint slide presentation of the major aspects of the Business Plan. It takes about an hour for a Neda representative to make the presentation. Please let us know if you would like us to make a presentation to your investment group.

## 3 The LEAP Protocols

The key component of our business plan is a set of mobile messaging protocols called the **Lightweight & Efficient Application Protocols**, or **LEAP**. LEAP is a set of high-performance, efficient protocols which are ideal for mobile and wireless applications. A detailed description of the LEAP protocols is provided in *The LEAP Manifesto* [?].

### 3.1 The Need for Efficiency

Engineering is the art of making intelligent trade-offs between conflicting requirements. A perennial engineering trade-off is that which must be made between the need for *simplicity*, and the need for *performance*. In the case of wireless data communications, performance means such things as data transfer speed, power efficiency, and bandwidth efficiency.

The 1980s and 1990s were the decades of simple protocols - protocols such as the aptly named Simple Mail Transfer Protocol (SMTP), and Simple Network Management Protocol (SNMP). Much of the success of these and other Internet protocols can be attributed to their simplicity. Simple protocols become widespread more easily than “high-performance” protocols, because it is easier to adopt and implement simple protocols than the more complex “high-performance” protocols.

However, things have changed. Network communications has now expanded into the wireless and mobile data communications arena, and *wireless applications demand efficiency*. The move to wide-area wireless has significantly shifted the location of the ideal engineering balance between simplicity and performance - moving it away from simplicity, and towards performance.

Wireless networks are constrained by bandwidth limitations, and the hand-held devices they serve are constrained by limitations such as display size, battery capacity, and memory capacity. These constraints place an extremely high premium on the efficiency of data transfer.

Existing Internet protocols do not provide the required efficiency. We therefore need a new generation of high-performance, efficient protocols, to cater to the demands of wireless applications. The point is sometimes made that the need for efficiency in the wireless arena is a temporary one – that advances in wireless engineering technology in the form of third generation (3G) systems will eliminate existing bandwidth limitations, obviating the need for efficient protocols. As long as the capacity of wireless networks remains finite, however, the need for efficiency will persist. Efficient usage is an inherent requirement for any finite resource, therefore the requirement for efficient bandwidth usage and battery longevity will remain.

### 3.2 Technical Overview of LEAP

The LEAP protocols are intended to be an enabling catalyst for the growth of the wireless-IP based Mobile Messaging industry, and have been designed with this goal in mind from the outset. They have been designed as a genuine enabling technology which will bring enormous benefits to the industry and the consumer. They are a sound engineering construction based on true openness and patent-freedom.

The LEAP protocols are a general-purpose solution to the problem of efficient message transfer, and their use is not limited to any particular device type or network. In particular, LEAP is compatible with all wireless-IP networks. Examples of wireless networks which provide native support for LEAP are CDPD, GSM, packet CDMA, and PCS.

The basic organization of the LEAP protocols is shown in Figure 1.

#### 3.2.1 The ESRO Layer: Efficient Transport Services

As shown in Figure 1, the LEAP protocols are layered. The lower layer is called **Efficient Short Remote Operations**, or **ESRO**. The ESRO layer provides reliable connectionless transport services which can be used for a variety of applications. For example, in addition to mobile messaging services, ESRO can also be used as a transport service for credit card verification applications and efficient micro browsers.

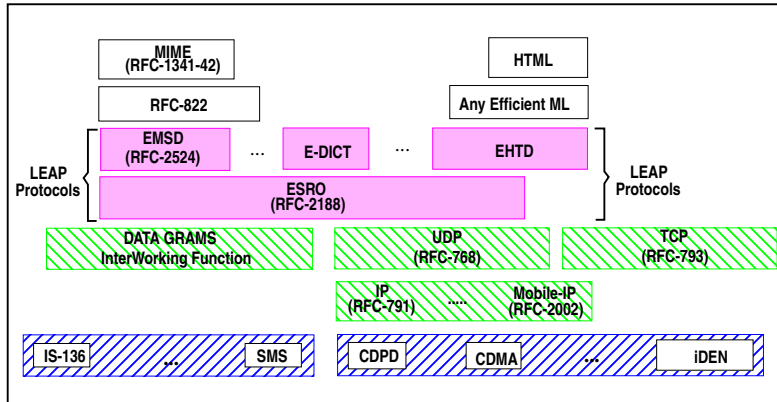

Figure 1: LEAP Protocol Organization

### **3.2.2 The EMSD Layer: Efficient E-Mail**

One of the efficient application layers built on top of ESRO is called **Efficient Mail Submission & Delivery**, or **EMSD**. EMSD is the component of LEAP that addresses the Mobile Messaging application.

EMSD is a specialized native Internet messaging protocol. It defines a similar set of services to the existing SMTP protocols. It defines a complete set of rules for message submission (end-user device to server) and message delivery (server to end-user device). EMSD meets or exceeds the level of functionality, reliability and security provided by the existing SMTP protocols.

Though its use is not limited to wireless networks, EMSD has been designed specifically to address the requirements of wireless networks, such as CDPD, Wireless-IP, and Mobile-IP. In particular, EMSD has been designed with a very strong and clear emphasis on efficiency.

EMSD is highly optimized for the submission and delivery of short (typically 4 kilobytes or less) Internet e-mail messages, and is therefore extremely well suited to the wireless environment. EMSD improves on existing messaging protocols by optimizing the exchange between the server and the end-user device, both in terms of the number of bytes transferred and the number of transmissions. Because of the required timeliness of the messages, mailbox access protocols like POP and IMAP are not used. EMSD is the only truly open messaging protocol that is specifically designed for the wireless network environment.

EMSD is a natural extension of the existing Internet e-mail environment, and accommodates the two-way paging model of usage, in which time-critical messages are "pushed" to the recipient.

Any network or network operator which faces significant bandwidth and capacity limitations can benefit from the use of EMSD. Any user of a network who must bear high costs for measured network usage can benefit from the use of EMSD.

The initial use of EMSD is expected to be primarily to provide Mobile Messaging services over IP-based wireless networks. However, EMSD can also function as an adjunct to Mail Access Protocols for "Mail Notification Services."

### **3.2.3 The EHTD Layer: Efficient Web Browsing**

The **Efficient Hyper Text Delivery**, or **EHTD**, layer is a hypertext transfer protocol which is optimized for the efficient transfer of short markup pages. EHTD is the component of the LEAP protocols which facilitates web browsing. Along with EMSD, EHTD also benefits from the reliable efficient services of ESRO. A multiplicity of efficient markup languages can be used in conjunction with EHTD. Development of the EHTD protocol is currently in progress.

### **3.2.4 Other Efficient LEAP Applications**

Various other efficient application protocols are either under development or anticipated for future development. One of these is the Efficient Dictionary protocol, or E-DICT, which will enable efficient access to dictionaries and other lookup data structures. A starting point for the E-DICT protocol is currently being created. In developing E-DICT, we intend to build on the existing work already done in the context of the DICT protocol.

We anticipate that additional protocols will be needed for a variety of future applications, not all of which can be foreseen at this time. These applications will include such things as efficient implementations of ESRO-based instant messaging, chat, white pages, and others.

## **3.3 Efficiency Characteristics of LEAP**

All LEAP protocols are designed with efficiency in mind. In this section we describe the efficiency characteristics of EMSD, the LEAP e-mail protocol. Other LEAP protocols deliver similar efficiency benefits.



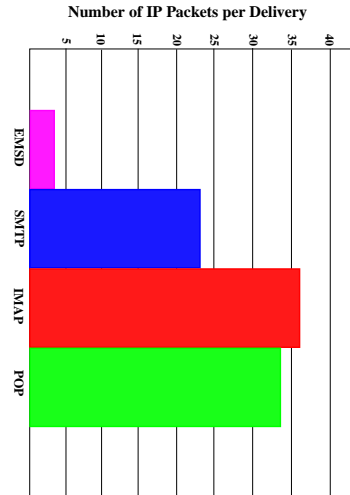

Figure 2: Protocol Efficiency Comparison

Most existing Internet e-mail protocols are designed with simplicity, rather than efficiency, as a primary design requirement. EMSD, by contrast, has been designed with efficiency as its primary requirement. For this reason, EMSD is a great deal more efficient than existing Internet e-mail protocols.

A set of detailed studies of the efficiency characteristics of EMSD is provided in the article entitled *Efficiency of EMSD* [?] within *The LEAP Manifesto*. In this section we will provide only a brief summary of some of the major results from that article. A comparison of the efficiency of the EMSD protocol to other messaging protocols is provided in Figure 2, which compares the delivery traffic overhead for EMSD to three other e-mail protocols: SMTP, IMAP and POP.

As the figure shows, EMSD is much more efficient than SMTP, POP and IMAP. For submission and delivery of short e-mail messages, EMSD is up to five times more efficient than the ubiquitous SMTP e-mail messaging protocols. Even with pipelining and other possible optimizations of SMTP, EMSD remains up to three times more efficient than SMTP.

By minimizing the network traffic required to send and receive messages, EMSD meets the needs of the mobile communicator. The extreme efficiency of the EMSD protocol translates into bandwidth efficiency, which in turn translates into:

- Efficient use of carrier bandwidth, and therefore increased capacity for network operators
- Longer battery life for mobile phones, PDAs and other wireless Internet devices
- Cheaper network usage costs for the end-user

- Reduced latency for the end-user
- Improved support for marginal coverage areas

### 3.4 LEAP: A Basis for Convergence

A detailed description of how LEAP will form the basis of the open Mobile Messaging industry is provided in the Manifesto article *Operation WhiteBerry*. In this section we provide a brief overview of the role of LEAP.

An illustration of how LEAP works is provided in Figure 3. As the figure shows, LEAP provides complete openness of interoperability among Mobile Messaging devices, wireless networks, and message centers (indicated by the abbreviation MC in the figure).

LEAP will thus have the effect of unifying the entire Mobile Messaging industry under a set of open Internet Protocol (“IP”) standards and protocols so that, in the manner of the World Wide Web, all of the Mobile Messaging networks will effectively operate as one.

In order to achieve this convergence, it is not sufficient for the Mobile Messaging industry merely to adopt a set of common protocols. Many would claim that WAP is in fact just such a set of common protocols. However, a further essential attribute of the required protocols is that they must be a truly integral, “end-to-end” part of the Internet, as opposed to “gateways” which accommodate unnecessary gatekeepers and middlemen.

LEAP is based on the concept of the Internet end-to-end model, in which direct communication between the client and the server assumes that the role of the network service provider is merely that of a pipe – i.e. a passive communication conduit. The Internet end-to-end model assumes that both ends are under the control and choice of the user, and that the servers are widespread, from a variety of providers, and under no specific administration or control. The Internet end-to-end model is in sharp contrast to the traditional phone company and telecommunications approach, which inserts gateways between the two ends, and creates control and exploitation opportunities for the telecommunications operators.

Bearing in mind that the natural convergence of all wireless networks to IP at Layer 3 is well under way and rapidly progressing, the key remaining requirements are: efficiency, lightweightness, miniaturization, and conformance to the Internet end-to-end model. LEAP fulfils all of these requirements. By serving as the necessary missing link, LEAP will become the ultimate basis for convergence.

The mobile e-mail component of LEAP is EMSD. In the spirit of the Internet end-to-end model, EMSD will facilitate the convergence of the two-way paging industry and Internet e-mail in a natural and transparent manner.

### 3.5 The End-User’s Experience

The entire LEAP family of protocols brings efficiency and functionality benefits to the users of miniaturized mobile devices. In this section we describe the user’s experience of an EMSD-enabled device.

Because of their frequent mobility, mobile users may not always have the benefit of a wired connection. They may have a permanent computing system elsewhere, at which they can review large messages at their leisure (for example, messages containing Word documents, Excel spreadsheets, images, etc.). While on the move, however, they need to be kept apprised of important information that requires their immediate attention. Such information cannot wait for them to find the time to set up a laptop and dial in to check for messages. They must be able to accept messages immediately, at any time, and on a device that they can carry anywhere.

LEAP provides mobile users with precisely this capability. Figure 4 illustrates how the Mobile Messaging needs of a typical user (we’ll call him Joe) are provided by the LEAP technology. This figure shows all the required technological components, and how they interoperate, in order to satisfy Joe’s messaging needs. The figure includes three major components:

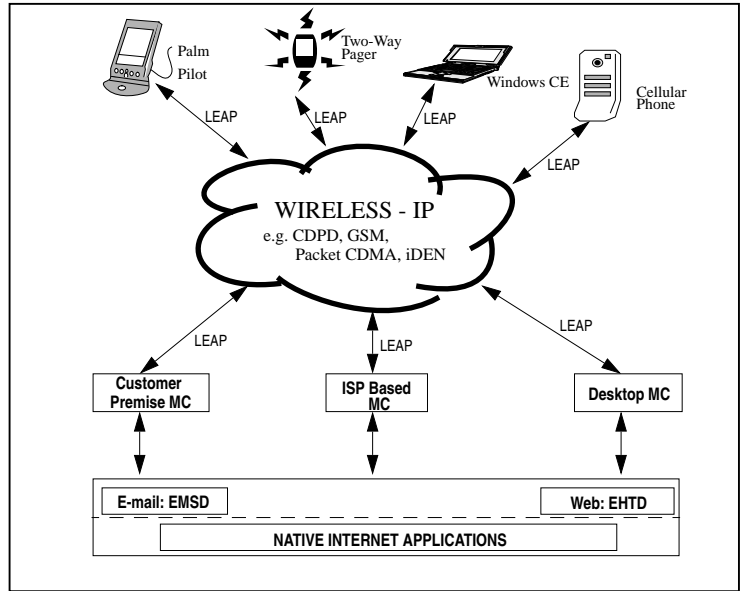

Figure 3: Open Mobile Messaging

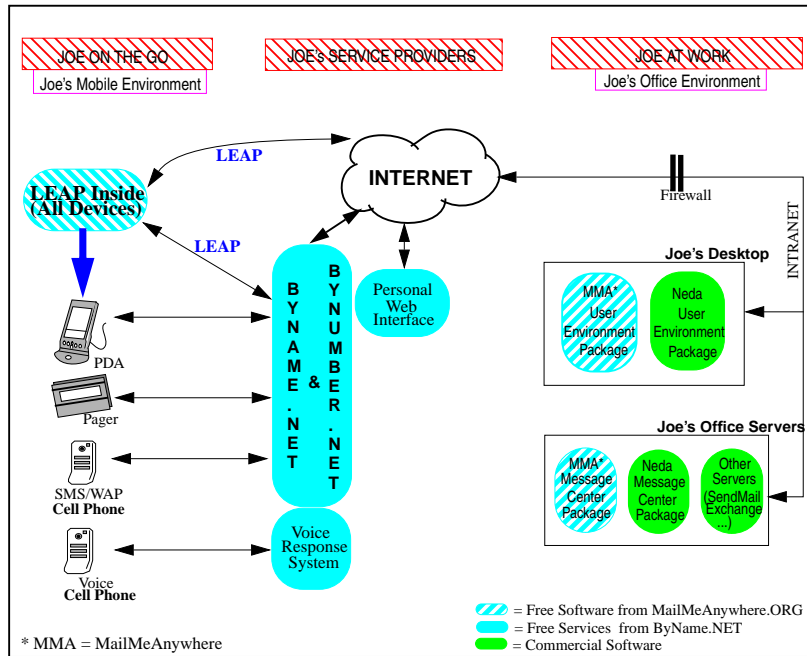

Figure 4: The End-User's Experience

1. First, Joe must equip himself with some form of mobile handheld device. This component is shown on the left side of the figure. The device must include the appropriate LEAP device software, allowing it to use the LEAP protocols to communicate with LEAP-enabled Message Centers, either directly over the Internet, or via a Subscriber Services system.
2. Joe also requires a set of Subscriber Services to support his Mobile Messaging capability. This component is shown in the center of the figure.
3. Joe may also wish to have LEAP-based Mobile Messaging capability on a Personal Desktop system at home, or on a Corporate Intranet system at his office. These components are shown on the right side of the figure.

Joe's mobile device could be a cell phone, a two-way pager, or a handheld device (such as a PalmPC) with a wireless (for example CDPD) modem. While the device can be turned off, the modem will remain on at all times to accept incoming messages.

Anyone with access to the Internet can now send a message to Joe. If Joe receives a generic (i.e. non-LEAP) e-mail message over the Internet, then the message will be fielded by Joe's Subscriber Service provider from the Internet e-mail system, using standard Internet protocols. The Service Provider will then forward the message to Joe's mobile device via the LEAP protocols.

Since the modem is always on, the message can be accepted at any time, and Joe can be notified immediately (in any of the ways commonly used for pager notification) that a message has arrived. He will then activate his LEAP device and read the message.

To send a message, Joe enters the message then submits it to the LEAP Service Provider via the LEAP protocols. The Service Provider then acts like a standard Internet Service Provider and sends the message to its destination.

Meanwhile, e-mails for Joe may be received in either his home or office mailbox systems. Joe may configure either of these systems to forward certain e-mails to his mobile device on a selective basis. If so, the qualifying e-mails will be forwarded to him directly over the Internet, using the LEAP protocols. The Subscriber Services system need not be involved in the transmission of these forwarded e-mails, since they are being sent from one LEAP-enabled system to another.

Joe's end-user device may have a limited display area and a limited keyboard. This is very much the case for today's cell phones, for example. If so, both the end-user and his/her correspondents may wish to make use of canned messages to facilitate their communication. These canned messages may be defined by the system or end-user device, or they may be defined by the message originator as embedded multiple-choice responses.

Note that the end-user experience described above represents a superset of the capabilities of the existing RIM BlackBerry [tm] system. In other words, the full functionality of the closed BlackBerry system can be reproduced and exceeded by the open LEAP protocols. The market success of BlackBerry has clearly demonstrated the large user demand for this kind of service. By providing the same functionality of BlackBerry in a completely open fashion, the market rewards will be much larger. For further discussion, see the article *Operation WhiteBerry* in *The LEAP Manifesto*.

### **3.6 The LEAP Development Process**

The LEAP protocols are intended to be open in the fullest sense of the word; they are intended to be freely and permanently available, subject to public review and revision, and without usage restrictions of any kind. Therefore the processes and procedures used throughout the development and maintenance of the LEAP protocols have been such as to endow them with these characteristics, and to ensure their integrity as public protocols.

A detailed description of the LEAP development process is provided in the article entitled *The LEAP Protocol Development Model* within *The LEAP Manifesto*. In the following sections we provide a brief summary of the major development principles.

### 3.6.1 Patent-Freedom

The development and maintenance of the LEAP protocols conforms fully to the policies and procedures of the Free Protocols Foundation. In particular, Neda has declared to the Free Protocols Foundation that the LEAP protocols are patent-free to the best of its knowledge, and that it intends to keep them patent-free permanently. For more information see <http://www.FreeProtocols.org>.

### 3.6.2 RFC Publication

Both protocols have been published as Internet RFCs; ESRO in September 1997 as RFC-2188 [?], and EMSD in March 1999 as RFC-2524 [?]. RFC publication is the mainstream Internet publishing procedure, ensuring that the protocols are freely, easily and permanently accessible to anyone who wishes to use them.

### 3.6.3 Open Maintenance Organizations

To provide an open forum for the continued development and maintenance of the LEAP protocols, Neda has established a public organization for each protocol.

The ESRO and EMSD protocols are maintained, respectively, by ESRO.org at <http://www.esro.org/>, and by EMSD.org at <http://www.emsd.org/>.

Each of these organizations allows public review of the respective protocol, and provides mechanisms for enhancement of the protocol as a result of collective experience.

Any interested person may participate in the further development of the protocols. Participation in the development process is entirely open and non-exclusive; there are no membership fees.

## 3.7 LEAPing over WAP

A set of specifications called the **Wireless Application Protocol**, or **WAP**, exists already, and purports to do the same things that LEAP does. However, the WAP specifications are entirely unfit for their claimed purpose, and are doomed to technological and political failure. A detailed criticism of WAP and justification of these statements is provided in an article called *The WAP Trap* [?] within *The LEAP Manifesto*.

LEAP is an alternative to WAP, that does in fact what WAP does only in fiction. For a point-by-point comparison of LEAP to WAP, see the article entitled *LEAP: One Alternative to WAP* [?] within *The LEAP Manifesto*.

Those characteristics of WAP that make it wholly unfit to be the industry standard are summarized in Table 1, along with the corresponding characteristics of the LEAP protocols.

## 3.8 A Brief History of LEAP

LEAP originated in 1994 as part of the research and development initiatives of McCaw Cellular's wireless data group (now AT&T Wireless Services). The development work that would eventually lead to LEAP was initially undertaken in the context of the CDPD network; its scope was later expanded to include the Narrowband PCS network also.

By 1996 McCaw Cellular was fully committed to paging, had recently purchased two nationwide narrowband wireless PCS licenses, and wished to develop an efficient wireless message transport and delivery system. Neda Communications, Inc., an independent consulting company working under contract to McCaw Cellular, played a significant role in the development of the required system. Neda Communications had also been involved from the outset in the development of the CDPD specification.

<b>WAP</b>	<b>LEAP</b>
Subject to known patent restrictions	Patent-free
Self-published by the WAP Forum	Published as Internet RFCs
Revisions subject to change without notice	All revisions permanently fixed
Maintained by the WAP Forum	Maintained by open working groups
Re-invention of existing protocols	Efficiency-optimizing extensions to existing protocols
Tailored to mobile phone user interface characteristics	User interface independent
Inherent security vulnerability	Imposes no security assumptions
Inconsistent protocol number assignment	Consistent protocol number assignment
Poor technical design	Good technical design
Initial focus: web browsing	Initial focus: messaging
Treats wireless as a special case	Treats wireless as an extension of Internet

Table 1: WAP versus LEAP

In 1997 however, soon after the purchase of McCaw Cellular by AT&T Wireless, the latter company abandoned the wireless messaging project. Prior to this event, Neda had secured from AT&T the necessary rights to continue independent development of the protocols. Therefore, recognizing the eventual future need for these protocols, Neda then undertook to continue development of them independently of AT&T. They were eventually completed by Neda, published as RFCs, and now form the basis of the LEAP protocols.

Prior to abandoning wireless messaging, AT&T Wireless Services invested several million dollars in related development work. In creating LEAP, therefore, Neda was able to build upon a large abandoned investment by AT&T Wireless.

## 4 The Opportunity

### 4.1 Scope: Building an Entire Industry

This business plan is about the creation of an entirely new industry: the Mobile Messaging industry. A rudimentary version of this industry already exists; products and services are available today which provide end-users with basic mobile messaging capability. However, the industry is characterized by a number of closed, competing, non-interoperating systems, and its growth is blocked by the absence of industry standard protocols.

The industry of today is a tiny fragment of what it is destined to become. Mobile Messaging is destined to attain the same degree of pervasiveness and cultural significance as e-mail and the wireless telephone. The corresponding business opportunity is gigantic.

Some indication of the size of this industry is provided by sales projections of just a single component of the industry: cellular phones. By the year 2002, global sales of wireless phones are expected to reach 700 million units, and there are expected to be a total of 1.4 billion wireless telephone users. And note that cell phones represent just one of a multiplicity of devices, services, and networks that will be used for mobile messaging.

### 4.2 The Time is Ripe

Our timing could hardly be better. Culturally and technologically, the time is perfectly ripe for the birth of the Mobile Messaging industry. From a cultural point of view, society has enthusiastically embraced two new technologies: e-mail

and the cell phone, and is now ready for the natural and inevitable combination of these two things.

And from a technological point of view, all the necessary technologies are in place except one: a powerful, enabling set of industry protocols. This is the vacuum that the LEAP protocols have been designed to fill.

### **4.3 An Attack on WAP**

The WAP fiasco has presented Neda with a golden marketing opportunity. Over the past 2 years, WAP has succeeded in doing two things. First, it has demonstrated the vital importance of common protocols. And second, by virtue of its own shortcomings, it has created a slowly increasing awareness that WAP itself is not the answer, and that there remains a crucial, unfulfilled industry need. It is precisely this need that Neda intends to satisfy.

In September 1999 we predicted that WAP would turn out to be a mess, and it has. We now make the following prediction: when first-generation WAP phones reach the U.S. market they will prove to be a major disappointment. They will turn out to be costly, their performance will fall far short of expectation, and they will be quickly recognized as a toy whose benefits are simply not worth the price.

WAP is already a sitting duck, and a lame one at that. One year from now it will be clearly moribund, to all but the most obtuse industry observers.

Neda intends to take full advantage of this opportunity by marketing LEAP as the only viable alternative to WAP. Our marketing strategy will consist of a direct, deliberate attack on the fraudulence of WAP. We will market LEAP against WAP based primarily on LEAP's patent-freedom and process integrity, and secondarily on LEAP's technical superiority.

Our direct attack on WAP is in sharp contrast to others who are sidestepping WAP or merely challenging WAP in peripheral ways (e.g. Xypoint's WAP-Free campaign). Others are avoiding a head-on challenge to WAP for two very good reasons: first, they do not have a viable alternative, and second, this presents certain business hazards.

We are well aware of what these hazards are. By joining the WAP Forum, many of the major Mobile Messaging players, such as AT&T, are apparently endorsing the WAP specification. A challenge to WAP may therefore be interpreted as a challenge to the investment strategy of the WAP Forum members, and may thus have very adverse consequences for any company that is also trying to sell to the WAP Forum companies. It is not a good business strategy to challenge your customer.

However, neither of these considerations is a deterrent to Neda. First, unlike other companies, we do have a viable alternative to WAP. Second, we do not regard membership in the WAP Forum as a genuine endorsement of the WAP specification. Many of the WAP Forum members are merely hedging their bets, and their membership means nothing. Third, WAP is a house of cards, and is therefore nothing to be genuinely feared in the long-term.

But finally, and most important of all, our high-profile challenge to WAP will provide Neda with incomparable name recognition, and a unique leadership role. These benefits are priceless. Our direct attack on WAP is a reasoned, rational component of our business strategy.

### **4.4 Hype versus Reality**

Our view of the evolution of the wireless Internet industry is illustrated in Figure 5. The early history of this industry is already known to us; in recent years the industry has undergone extremely rapid growth. And in the long term, there is general consensus among analysts that the industry is destined for continued strong and sustained growth.

So the early history is known, and the eventual history we can predict with confidence. But what about the more immediate future? Our view is that, largely thanks to the WAP Forum, the industry has been significantly over-hyped, with the result that expectations now greatly exceed realities. Our prediction is that this period of soaring expectation will be followed by a period of general disillusionment and frustration, as these expectations are inevitably disappointed.



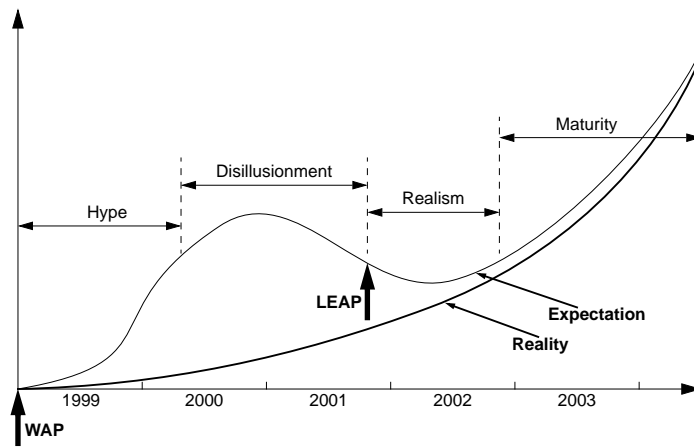

Figure 5: Wireless Internet Hype vs. Reality

Sooner or later the industry must adopt a more realistic understanding of its technological and business challenges. Part of this understanding will consist of the recognition that the wireless industry must adopt a single set of truly open protocols. Only then will the industry be able to undergo stable and sustained growth.

WAP represents the era of hype and disillusionment. LEAP represents the era of realism and maturity.

## 5 Business Model and Strategy

One of the least traditional aspects of our business model is the great advantage we are taking of the power of openness. We are enlisting the power of openness to achieve our goals throughout our business model, by means of open protocols, and open-source software. Even the Business Plan itself has a high degree of openness; there is little need for secrecy in the plan.

In particular, a critical part of our business strategy is our use of open-source software to promote usage of the LEAP protocols.

### 5.1 Nomenclature: Free Software and Open-Source Software

Throughout this business plan, we will make frequent use of the terms **free software**, and **open-source software**. These terms are often used informally and casually in the software industry, and may have several different meanings. For example, the term open-source software is often used to indicate merely that the source code is available. When we use the term open-source, however, we are using a much stricter definition than this.

Our definitions of the terms free software and open-source software are consistent with those of the Free Software Foundation and OpenSource.org. Throughout this business plan, we will use these terms with the following definitions:

**Open-source software** refers to software for which the source code is readily available. Either the software must be distributed as source code *per se*, or the source code must be readily available from some other source. Also, the software must be distributed under a license which does not restrict the selling or re-distribution of the software as a component of an aggregate software distribution. The license may not require any fee or royalty for such sale. Finally, the license must allow modification and the creation of derivative works, and must allow them to be distributed under the same terms as the original license.

The above describes only the essential, key characteristics of open-source software. For a complete and detailed definition, see <http://www.opensource.org/osd.html>.

**Free software** is software which the user is free to run, copy, distribute, study, change, and improve. For a complete and detailed definition, see <http://www.fsf.org/philosophy/free-sw.html>.

Note that in the term “free software,” the word “free” is being used to indicate the concept of *liberty*, rather than that of *without cost*. In other words, we mean free as in “free speech,” rather than “free beer.”

### 5.2 The Open-Source Software Puzzle

The enormous power of Open-Source Software (OSS) has been well demonstrated by the tremendous success of such OSS systems as Linux, Imap, Sendmail, and various others. At this point it seems clear that creating a rich and powerful software system, then providing it in the form of patent-free, open-source software, at no cost to the user, is an extremely effective mechanism for encouraging its adoption and usage.

For further discussion and information about the Open-Source Software movement, see article [?]. Also, a particularly revealing analysis of OSS is provided by Microsoft’s infamous Halloween documents, [?], [?]. These leaked documents provide embarrassingly revealing insights into Microsoft’s viewpoint and attitude towards the threat posed by OSS.

But what remains a puzzle is this: How can one make money from the OSS model? Four basic business models have been proposed in answer to this:

1. **Provide Secondary Services.** The vendor/developer of the OSS system makes money by means of service contracts, customer integration, etc.
2. **Loss Leader for Market Entry.** The vendor/developer of the OSS system uses the advantages of the OSS process (especially that of credibility) as a competitive advantage against established commercial vendors.
3. **Commoditizing Downstream Suppliers.** The vendor/developer of the OSS system is also the producer of a product or service further in the value supply chain, and closer to the consumer.
4. **Standards Preemption.** Because the OSS process can be argued to be a winner-take-all process, it may be to the advantage of the vendor/developer to seed the OSS market with its own codebase, so as to preempt a competitive codebase from taking hold.

These four models represent the current status of business thinking regarding the possible business advantages of the OSS model. All four of these business models are valid, and each represents a practical, workable business strategy. But none of them can stand on its own as the basis for a company business plan.

In Neda's business plan, however, we are proposing an extension to these four mechanisms that not only sustains a business, but also leads to the creation of an entire industry. Essentially, we will combine and focus all four of the above mechanisms into the achievement of a single, ultimate goal: acquiring leadership of the Subscriber Services business.

We believe that ours is the first true, OSS-based business model, conceived as such from the beginning. This is the first plan to combine the tremendous power of the OSS model with an explicit, large-scale profit-making business plan.

### 5.3 The Supply Chain Model

According to conventional supply chain analysis, a successful business model must satisfy the financial and other needs of all potential gatekeepers throughout the supply chain.

If the protocol-based Mobile Messaging industry were to be looked at from the traditional supply chain point of view, the picture would look something like Figure 6. This figure shows the supply chain relationships among all the major players in the Mobile Messaging industry. According to the conventional wisdom, in order for a business model to work, it is necessary (though not sufficient) for all the companies in the chain to make profits and satisfy their non-financial needs. In the protocols-based model, the LEAP protocols, shown at the bottom of the figure, are the basic enabling technology for the entire industry. The Consumers, shown at the top of the figure, are the ultimate end-users of the industry products and services. In general, products and services flow from the bottom of the figure towards the top, while revenues flow from the top down towards the bottom.

Some of the key Mobile Messaging industry constituencies are the Modem Manufacturers (e.g. Novatel), the PDA Manufacturers (e.g. Palm), and the Network Service Providers (e.g. AT&T). However, it is integrators such as OmniSky, who are bundling fully integrated solutions and focusing on direct Layer 7 relationships with the consumer, who are best positioned to exploit the increasing returns opportunities of the Virtual Communities phenomenon [?]. If we were to adopt the Supply Chain model, this is the position that Neda would target to occupy.

Much of the success of WAP can be attributed to the WAP Forum's masterful manipulation of the traditional supply chain model, and to their winning the support of all the relevant gate-keepers. The creation of the WAP Forum, and their accommodation of all the significant network operators, is the classical business execution of what is needed to make the supply chain work in one's favor.

Our approach is completely different. By adopting the OSS model, we bypass the traditional gatekeeper roles altogether, thereby rendering them irrelevant. Those gatekeepers who do not recognize that the end-to-end Internet model will make their gatekeeper role obsolete will sooner or later find themselves out in the cold. All four of the OSS models described in the previous section will fulfill their respective purposes. The OSS model is an extremely powerful force which will act in favor of the acceptance and usage of LEAP. In addition, the Internet end-to-end model, which eliminates the WAP-like gateway model, will also greatly favor the usage of LEAP.

In the telecommunications industry, the accommodation of gate-keepers and supply chain models have been traditional requirements of any business plan. However, we do not consider that tradition to be relevant in the context of LEAP. Instead, we consider that our main challenge will be to fully understand and exploit the power of the Internet end-to-end and OSS models.

## 5.4 Business Model: A Dichotomy

We have created LEAP, a set of Mobile Messaging communications protocols, which will become the Mobile Messaging industry standard, and will catalyze enormous growth of this industry. Neda's name recognition and first-mover advantage will place it in prime position to capitalize on this growth.

This raises two fundamental questions:

- How will we ensure that the LEAP protocols become the industry standard?
- How will we profit from this?

Our business model provides the answers to both of these questions. However, the answers to these two questions are very different, and this represents the basic dichotomy of our business model.

The answer to the first question is that the protocols will become the industry standard because of the effects of two powerful forces: (i) the open and patent-free nature of the protocols themselves, and (ii) the distribution of software implementations of the protocols in the form of Open-Source Software (OSS).

The answer to the second question is that we will profit initially from sales of LEAP software, systems and technology licenses. Then, as the industry matures, our revenue stream will shift to Subscriber Services, as the major long-term profit-making opportunity.

The patent-free nature of the protocols allows them to be adopted and implemented by any user without legal or financial hindrance of any kind. This gives them an enormous advantage over any competing patented protocol – such as WAP, for example.

Furthermore, implementations of the protocols for all major system platforms will be provided by Neda in the form of open-source software, at no cost to the user. Since the software is free, it has an enormous market advantage over proprietary, for-profit software implementations. The OSS model has been proven to be a powerful and effective mechanism for promoting software usage.

The use of the twin mechanisms of patent-freedom and the OSS model to promote the LEAP protocols as the industry standard represents the first half of our business dichotomy. A complete description of this half of our business model is provided in a separate document called *The LEAP Manifesto* [?]. This document describes LEAP and its propagation mechanisms in detail. It can be thought of as the public side of our business model, while this business plan is the private side.

## 5.5 Business Model: Highly Unconventional

Our business model thus represents the marriage of two things: (1) the use of patent-freedom and the OSS model to catalyze the growth of an industry, and (2) an explicit business plan for profiting from this growth.

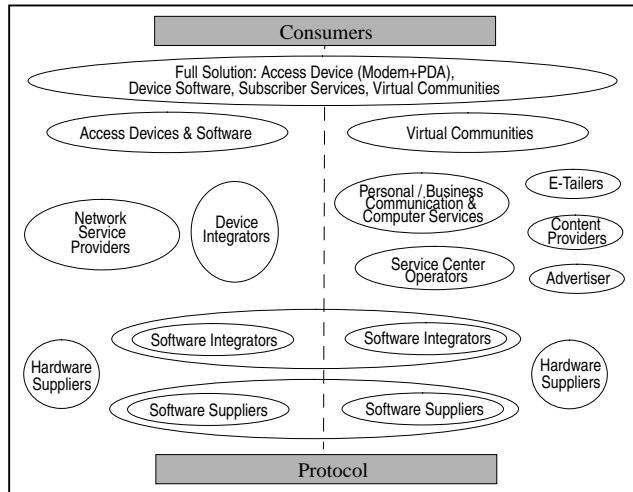

Figure 6: Traditional Supply Chain Model

On the face of it, these two things do not appear to fit well together. Since patent-freedom and OSS both imply a relinquishing of ownership, neither would appear to be conducive to the generation of business profit. For this reason, the use of the OSS model has traditionally been considered to be fundamentally incompatible with business profit-making.

Indeed, as author Vinod Valloppillil comments in the now infamous Microsoft Halloween documents [?] [?],

Notice, that no case of a successful startup originating an OSS project has been observed. In (previous) cases, the OSS project existed before the startup was formed.

In other words, the OSS (Open Source Software) concept has never been an integral part of a successful business model *ab initio*. Neda's business model, however, has precisely this structure. It is the first business model to incorporate this structure on such an ambitious scale, and is therefore without precedent.

The resolution to the apparent conflict, of course, is quite simple: we will not be making our money by virtue of patent or software ownership; we will be making it some other way. However, the key to our business success lies in the acquisition of mindshare via the widespread usage of the LEAP protocols. Therefore, the first half of our business model consists of a strategy to accomplish exactly this.

This half of our business model contains no profit motivation whatsoever. Instead, we are motivated by only a single consideration: to promote the widespread usage of LEAP throughout every segment of the Mobile Messaging industry: over all major wireless networks, in all major handheld devices, and in a variety of Message Center platforms. And there is no better way to do this than by means of patent-freedom and OSS.

Because of its goals and methods, the first half of our business model represents a complete upending and reversal of traditional business models. In particular:

- Traditional business thinking considers patent ownership to be desirable, as a means of protecting a business's intellectual property assets. We view patents as extremely undesirable, since they act as an inhibiting force on the adoption of LEAP and the growth of the industry.
- Traditional business operation seeks to maintain secrecy regarding a company's plans. Our business model calls for complete disclosure of the public side of our model, since public exposure serves to increase awareness and usage of LEAP.
- Traditional thinking is that competition is to be feared. In our case vigorous competition is greatly to our advantage, again, since this has the effect of increasing LEAP usage.
- In the traditional business model, a key notion is that of sustainable advantage. Our business success in the face of competition is predicated upon our first-mover position, name recognition, and fitness in the face of competition.
- In the conventional entrepreneur/VC relationship, the participation of the VC is an essential pre-requisite to the execution of the entrepreneur's plans – without the VC, the entrepreneur cannot move forward. In our model the use of patent-freedom and OSS is sufficient to promote the adoption of LEAP even without external financing.

We are thus breaking many of the cherished rules of the business and VC world; we are slaughtering sacred cows left and right. The role played by the OSS model in our plan dictates that we do so. The success of OSS depends on freedom and openness. It requires a deliberate relinquishing of control by its creator; something which is highly counterintuitive to the traditional business precepts of ownership and control.

For these reasons, Neda is not a conventional company, and this is not a conventional business plan.

### 5.5.1 Separation of Interests

The combination of the principles of patent-freedom and openness on the one hand, with a profit-making business operation on the other, presents an apparent conflict of interest.

A key element of our strategy consists of the openness and patent-freedom of the LEAP protocols. For this reason we have not applied for any patents related to the LEAP protocols, nor do we intend to. Furthermore, we have made a declaration to the Free Protocols Foundation that the protocols are, and will remain, patent-free. We have also published the protocols as Internet RFCs.

Our business model thus requires that we maintain two very different and potentially conflicting mindsets: one, the academic mindset of belief in patent-freedom and open-source software; and two, the practical mindset of the successful businessman.

We achieve this duality of attitude, and resolve any possible conflict of interest, by separating responsibility for these two different components. We provide full support for freedom and openness via the Free Protocols Foundation; and we exercise business leadership via Neda Communications, Inc.

By means of our commitment to the principles of the Free Protocols Foundation we ensure the freedom, openness and success of the LEAP protocols. And by playing the role of businessmen within Neda Communications, Inc., we are able to profit from this by whatever business strategy we see fit, provided we do not in any way violate the principles of the Free Protocols Foundation.

## 5.6 An Industry-Building Blueprint

History has demonstrated clearly that in the Internet world, the protocols which achieve eventual dominance are those which are open and support the Internet end-to-end model. This has been demonstrated by such protocols as IP, TCP, SMTP, HTTP and others. For a historical analysis of several protocols, supporting this conclusion, see the article entitled *Lessons From History: Comparative Case Studies* within *The LEAP Manifesto*.

A historical summary of various protocols is provided in Figure 7. The protocols are arranged in groups, where each group represents a set of competing protocols. The table lists the major characteristics of each protocol, along with its ultimate success or failure. Note that there is only one eventual winner in each group. Note also how certain characteristics correlate extremely well with eventual protocol success. In particular, in all cases the winning protocol was fully open (patent-free, open publication method, open maintenance organizations), and open-source implementations were readily available. These historical case studies demonstrate the power of open protocols and open-source software, and are the precedents for our business model.

Further discussion and analysis of Figure 7 is provided in the article *Lessons From History: Comparative Case Studies* within *The LEAP Manifesto*.

Despite these precedents, however, thus far no one has developed a set of protocols which are truly open and patent-free, while simultaneously writing a business plan which takes explicit advantage of the leadership and name recognition associated with the protocols.

For this combination to be successful it is necessary to fully understand two separate and traditionally disjoint value systems and models. These two value systems are:

1. The ideology of the Internet Technical Community
2. The ideology of the Business Community

Our blueprint for building the protocol-based Mobile Messaging industry includes both of these value systems. Figure 8 shows how all the different pieces of our blueprint fit together.

In the center of this figure are the protocols themselves, patent-free and published as Internet RFCs. Engineering support for the protocols is through EMSD.org and ESRO.org. General promotion and support for the protocols is through LeapForum.org. Device software and Server software in open-source form is available for a variety of platforms.

The business value system is shown surrounding the technical Internet value system. On the business side, the availability of software in the form of supported and plug-and-play products is simply a starting point. The really big opportunity is in the Subscriber Services area.

There is nothing significantly new in either the technical center of Figure 8 or the surrounding business framework. But the planned coordination between the two is new, unique, and very powerful.

## 6 The Company

### 6.1 Incorporation History

Neda Communications, Inc.<sup>1</sup> was initially founded in 1991. In 1999, however, the company was reincorporated as a new legal entity, appropriately structured for financing. The law firm of Van Valkenberg Furber Law Group (VVFLG) worked closely with Neda to create a state-of-the-art corporate structure, representing a clean and orderly starting point for external financing.

Legally, therefore, the company is less than one year old; however, it has inherited all the technology and business assets of nine years of successful operation. At this point the company has the benefits of its maturity and technology assets, while also being an orderly vessel for financing. Thus far, Neda has been entirely self-financed.

Throughout this document we will use the name “Neda” to refer both to the former, pre-reincorporation company, and the the new, post-reincorporation company, despite the fact that these are two different legal entities. It will always be clear from the context which entity we are referring to.

Neda has obtained all necessary federal and state permits and licenses to operate its facilities. There can be no assurance that Neda’s operation and profitability will not be subject to more restrictive regulation and increased taxation by federal, state, or local agencies.

### 6.2 Operational History

Neda has a proven track record of technical proficiency and profitability. Between 1991 and 1997 Neda operated as a successful data communications consulting company, with an average income from 1993 to 1997 of over \$1 million annually.

Neda has been actively involved in the wireless data industry since 1992. From 1992 through 1994 Neda acted as the lead designer and primary architect of the Cellular Digital Packet Data (CDPD) System Specifications. From 1994 through early 1997, Neda designed and implemented much of AT&T Wireless Services mobile messaging prototype software and systems, for use over Narrowband PCS and CDPD wireless networks.

In March of 1997, however, AT&T Wireless Services abandoned its Narrowband PCS two-way paging network, called pACT. Prior to this event, in August of 1996, Neda and AT&T Wireless Services had signed the equivalent of a Value Added Reseller (VAR) agreement, which enabled Neda to produce and market derivative work from the software base that was developed with AWS funding.

Recognizing its future potential, Neda then undertook to continue this development work independent of AT&T. In 1997, therefore, Neda substantially curtailed its consulting activities, and since then has been actively developing the

---

<sup>1</sup>Neda is a Farsi word which roughly translates to: “a short, pleasant message”



assets required to implement this business plan. This business plan represents a blueprint for Neda's transition from a consulting company, initially into a product-based company, then subsequently into a Subscriber Services company.

For the past nine years our vision and focus has been the creation of protocols, software and systems which facilitate interpersonal messaging. As an example of our early vision, note that NEDA.COM was registered before MICROSOFT.COM:

\$ whois neda.com	\$ whois microsoft.com
Registrant:	Registrant:
Neda Communications, Inc.	Microsoft Corporation
(NEDA-DOM)	(MICROSOFT-DOM)
17005 S.E. 31st Place	One Microsoft Way
Bellevue, WA 98008, US	Redmond, WA 98052, US
Domain Name: NEDA.COM	Domain Name: MICROSOFT.COM
Record Created On 20-Mar-91	Record Created On 02-May-91

### 6.3 Company Mission

Neda's short-term mission is to promote the LEAP protocols as an alternative to WAP.

Our intermediate-term mission is to play an instrumental role in the creation of the wireless-IP based Mobile Messaging industry, and to become a major provider of software, systems and services for non-intrusive interpersonal communication.

Our long-term mission is to claim the Wireless Application Service Provider (WASP) market based on the success of the LEAP protocols.

### 6.4 Company Values

On the one hand we recognize that:

*21st Century planet Earth is too complex to be governed by anything but economics*

On the other hand:

*Economics is the study of what people do when nothing more important than money is at stake<sup>2</sup>*

Both of these ideas are contained within the philosophy of Neda.

One of our key company values is pride in our technical proficiency. We are committed to producing quality software and systems that fully meet the requirements of our clients and customers. We have a proven ability to build, maintain and improve complex, stable systems.

We are also strong believers in patent-free protocols and software, and in open-source software. We are both users of, and contributors to, the open-source software movement. We believe in pursuing business success by means of competition in an open and fair environment.

Because of this combination of values, technical proficiency, experience, assets and vision, we are uniquely qualified to play a leadership role in the creation of the Mobile Messaging industry.

---

<sup>2</sup>Richard Stallman

Note that this business plan was written by the same people who designed the free protocols, wrote the RFCs, and designed the software implementations. Typically, the people who create technical constructs such as RFCs and those who create business contracts such as business plans have very different sets of goals and value systems.

At Neda, we claim to be unique in that each of the principal team players has a clear understanding of, and respect for, the importance of both value systems.

## **6.5 Technology Balance Sheet**

Over the past nine years we have created a large quantity of technological assets. These assets include all the protocols, software and systems required to execute this business plan.

All of our technological assets are directly related to our goals for the creation of the Mobile Messaging industry. Our assets are coherent, strategic, complementary and tightly focused. Together, they create the enormous potential that we claim in this plan.

A complete summary of our technological assets is provided in Appendix C.

### **6.5.1 Marketing Agreements**

Neda has a non-exclusive marketing agreement with AT&T Wireless Services. In August of 1996, Neda and AT&T Wireless Services signed the equivalent of a Value Added Reseller (VAR) agreement which enables Neda to produce and market derivative work from the software base that was developed with AT&T Wireless Services funding.

## **6.6 Recent Licensees**

Since 1997 we have devoted our energies to the creation of the assets required for this business plan, and have not been making an active effort to generate revenue. However, we have already sold a number of licenses as a result of word of mouth communications, and the foresight of clients and business partners who share our vision of the future. Also it has often been the case that a consulting relationship has led to the sale of licenses to a client, and vice versa. Our most recent licensees are:

- Xypoint Corporation (VoRDE)
- INETCO Systems (ESRO)
- AT&T Wireless Services – Messaging Division
- Sema Group UK

In addition to the above licensees, several of our business partners have obtained temporary and/or evaluation licenses for various components of LEAP. These include:

- Sierra Wireless
- BC Tel Mobility
- AT&T Wireless Services – Wireless Data Division (WDD)
- PCSI
- Novatel

For more information, see Appendix D.

## 6.7 Recent Client List

Neda has had a long history of successful and profitable consulting relationship with a variety of clients. Among our satisfied consulting services clients are:

- INETCO Systems
- Sierra Wireless
- Geotek
- AT&T Wireless Data Division (WDD)
- AT&T Messaging
- AT&T Corporate
- CDPD Forum
- Data Critical
- Electronic Mail Associations (EMA)
- Emulex
- Motorola – WDG
- Microsoft
- XYpoint
- Cosant

For more information, see Appendix E.

## 6.8 Relationship with the Free Protocols Foundation

The mission of the Free Protocols Foundation (FPF) is to prevent the creation and promotion of patented protocols. The FPF provides a mechanism whereby a protocol developer may ensure, insofar as possible, that the resulting protocol is patent-free, and also provides a public forum whereby the developer may declare that the protocol is intended to be patent-free. The FPF thus provides some measure of independent, third-party assurance that a particular protocol is patent-free.

Any company, organization or individual is free to make use of the FPF policies and procedures for these purposes. Neda subscribes fully to the philosophy and goals of the FPF, and has used its procedures to ensure that the LEAP protocols are patent-free, and to make a public declaration to that effect.

Though Neda has made use of the FPF policies and procedures, no business or legal relationship exists between Neda Communications Inc. and the Free Protocols Foundation. Mohsen Banan, the President of Neda, is also currently a board member of the Free Protocols Foundation, along with Richard Stallman and Pinneke Tjandana. However, Mohsen Banan's roles in the two contexts are separate and without conflict.

## 6.9 The Team

Neda Communications, Inc. maintains a core technical and management team with direct knowledge and experience in the fields of electronic messaging, mobile computing, and data communications. The Neda management team is led by Mr. Mohsen Banan.

A brief description of each member of the Neda team is provided below. A more detailed biography for each person is provided in Appendix A.

**Mohsen Banan**, engineer and entrepreneur, has been running Neda since 1991. From 1983 to 1991, he worked as a software engineer for nine different companies. Mohsen's recent publications include RFC-2524, RFC-2188, and Internetwork Mobility, published by Prentice-Hall. From 1992 to 1995 Mohsen led the technical architecture design for the CDPD specifications. Mohsen has also developed a large body of free software and open-source code with an emphasis on efficiency. Mohsen's current obsession is the propagation of LEAP. In addition to being an engineer, Mohsen has also played the roles of businessman, manager, and accountant. Mohsen dropped out of the Ph.D. program in Electrical Engineering at the University of Washington in 1983.

**Pean Lim** and Mohsen started working together in March of 1990 at Teknekron. Their common religious beliefs in Emacs and E-Lisp helped to sustain their friendship over the years. Pean joined Neda in 1996. Pean's career has been focussed on the Internet and Unix. He received his Master's in Computer Science from MIT in 1986 and has 15 years of engineering experience.

**John Urrutia** has been assisting Neda with its accounting and tax planning needs since 1995. John and Mohsen attended Seattle University from 1978 to 1981. John joined Neda as the CFO in 1999. John Urrutia is a CPA with 18 years of experience, and he ran his own CPA Accounting firm for 12 years.

**Andrew Hammoude** and Mohsen were both in the Electrical Engineering Ph.D. program at the University of Washington in 1982. Unlike Mohsen, Andrew stayed in the Ph.D. program and completed his doctorate in 1988. Over the years Andrew and Mohsen kept in touch, and Andrew began working as a consultant to Neda in 1999. Andrew's diverse engineering background and business experience make him an ideal asset to Neda at this stage of its development.

**Joe Pruskowski** hired Mohsen to work at InterConnections as a software engineer in 1988. Over the years, Joe has been a mentor to Mohsen in various business-related matters. He has been an advisor to Neda since 1998. Joe was the co-founder of InterConnections and CacheFlow. CacheFlow went public in 1999; InterConnections was bought out by Emulex in 1994. Joe is also a business advisor to numerous local companies.

**Murat Divringi** was Mohsen's immediate supervisor at InterConnections in 1988. He supervised Neda's consulting work to Emulex until 1994. He worked for Neda in 1996 and 1997. Murat joined CacheFlow in 1997, but continues to provide assistance to Neda. Murat received his Master's degree in Electrical Engineering from RPI in 1984. He is a seasoned and disciplined engineering manager.

**Pinneke Tjandana** joined Neda fresh out of school in 1998. She maintains Neda's numerous websites, functions as a technical assistant to Mohsen, and performs many other vital functions for Neda.

**Mark McWiggins** and Mohsen worked together as software engineers at Teltone in 1984. Mark has been doing consulting work to Neda since 1992. Mark specializes in taming large e-mail systems. He has more than 15 years of Unix system administration experience.

## 6.10 Outside Support

**Van Valkenberg Furber Law Group P.L.L.C. (VVFLG)**. Behind every successful company is a good law firm. VVFLG has provided legal representation to Neda since June 1999. VVFLG has established a state-of-the-art corporate structure for Neda which fully and properly prepares it for financing by professional investors. Brad Furber, partner in VVFLG, has been actively advising Neda in the area of investor relations. For more information, see Section

## B.1.

**Perkins Coie** has been assisting Neda with licensing and contractual work since 1995. Over the years, Bruce Dick and Mohsen have worked together closely and developed an efficient working style. For more information, see Section B.2.

**pr.com** and **BlueSky** are two public relations companies with whom Neda has had recent discussions. Both of these companies have an understanding of Neda's public relations needs, have appropriate experience in the wireless field, and are interested in working with Neda. They are both candidates for our public relations firm.

## 7 Strategic & Financing Options

### 7.1 Mobile Messaging Market Segments

The LEAP-based Mobile Messaging industry can be viewed as four largely independent market segments:

1. Protocols & Technology Market
2. Device Software Products Market
3. Message Center Software Products Market
4. Subscriber Services

We will provide further descriptions of these market segments as we describe our strategy for approaching each of them in subsequent sections of this business plan.

The above are four distinctly different markets. However, an approach that targets all four markets in parallel can be executed without presenting significant management difficulty. From a strict business operations perspective, three Business Units (one protocol-oriented, one products-oriented, and one Subscriber Services-oriented) can be put in place to address the entire Mobile Messaging industry, with little or no overlap or conflict.

It is also important to note that these four market segments are very different in terms of their expected growth pattern. Three of the four markets, namely (1) - (3) above, are essentially conventional product-based markets, and can be expected to exhibit a more or less linear growth pattern.

The Subscriber Services market, however, is radically different. It is an inherently increasing returns market, and can therefore be expected to exhibit an exponential growth rate. It is this characteristic of Subscriber Services that guides Neda's business strategy, as described below.

### 7.2 Three Strategic Options

There are many ways in which the Mobile Messaging industry can be approached from a strategic business perspective. However, there are three major strategic options in particular which make the most sense from a return-on-investment point of view. We refer to these as:

1. The Protocol-Based strategy
2. The Product-Based strategy
3. The Subscriber Services strategy

<b>Activity</b>	<b>Strategy I Protocol-Based</b>	<b>Strategy II Product-Based</b>	<b>Strategy III Subscriber Services</b>
Protocol Spec. Maintenance & Promotion	XXXX	XX	XX
Protocol Engines Software	XXXX	XXXX	XXXX
Device Software Products	X	XX	XXXX
Message Center Software Products	X	XXXX	XXXX
Subscriber Services	X	XX	XXXXX

Table 2: Three Strategic Options

Each of these strategies represents a logical, coherent plan of action for capturing a particular subset of the Mobile Messaging industry. All three are based on making the LEAP protocols widespread. The differences among them are in the different degrees of emphasis placed on each of the four Mobile Messaging market segments.

The three strategies are illustrated in Table 2. The left hand column of this table lists the various activities that will form part of each business strategy. Four of the listed activities correspond to the four market segments described above; in addition, the table lists a fifth activity: Protocol Specification Maintenance & Promotion. This activity refers to technical development and maintenance of the protocols. This does not correspond to any of the four market segments; however it is an essential component of each strategy. In Table 2, the number of X's in each cell indicates the amount of investment made in each activity, under each business strategy.

Note that each of the activities listed in the first column of Table 2 falls within one of the three Business Units mentioned above: protocol-oriented (Protocol Specification Maintenance & Promotion, Protocol Engines Software); products-oriented (Device Software Products, Message Center Products); or Subscriber Services-oriented (Subscriber Services).

### 7.2.1 Strategy I: The Protocol-Based Strategy

The Protocol-Based strategy capitalizes on the power of the Open-Source Software model. In this strategy, Neda distributes nearly all of its software in the form of Open-Source Software, under some type of “free” software license. We then make the LEAP protocols widespread by following one of the well-known successful models of this approach, such as Imap, Linux, Sendmail, Bind, etc.

The major advantage of the Protocol-Based strategy is that it requires very little money. If necessary this strategy can be entirely self-financed. Alternatively, with up to \$1.5M, its schedule can be significantly accelerated. Furthermore, this strategy and its details are well understood by the Neda management team, and can be executed by us quite easily.

On the other hand, the Protocol-Based strategy represents only a very modest ambition, given the enormous size of the Mobile Messaging industry. Under this scenario Neda would benefit significantly from its leadership role and from LEAP name recognition, but would remain a relatively small company. Nevertheless, the financial benefits of this approach are still very substantial.

In effect, the Protocol-Based strategy is what Neda has been doing thus far, and is what Neda will continue to do if necessary without external financing.

### 7.2.2 Strategy II: The Product-Based Strategy

The Product-Based strategy places heavy emphasis on the device and message center software businesses, and also places some increased emphasis on the Subscriber Services business. Under this strategy, certain selected parts of the software business remain proprietary to Neda, while other parts remain “free” as under the Protocol-Based strategy.

The Product-Based strategy relies heavily on industry partnership-building by Neda, and is therefore very deal

intensive. It is based on the Keiretsu model.

The Product-Based strategy requires significant external financing, but much less than Strategy III. However, a major advantage of this strategy is that it has great flexibility, and can readily be tailored to the amount of financing available.

### **7.2.3 Strategy III: The Subscriber Services Strategy**

As shown in Table 2, the Subscriber Services strategy pursues all four Mobile Messaging markets aggressively and simultaneously. It is the ultimate strategy in terms of scope, ambition, and reward. In effect, under this scenario, Neda becomes the Netscape of Mobile Messaging.

By placing all four activities under a single management, their development can be mutually synchronized, and business development can take place smoothly and rapidly. A very clear and distinct value proposition can be presented to customers and clients.

The Subscriber Services strategy requires an initial \$15 million in external financing. It also requires the participation of the biggest players and leaders within the industry.

Note that to some extent it is possible to progress from one of these strategies to another. For example, it is possible to begin execution of the Protocol-Based strategy, then progress to either of the other strategies as adequate funding becomes available, or as the industry landscape changes.

## **7.3 Neda's Choice: The Subscriber Services Strategy**

Neda's intention is to pursue Strategy III: the Subscriber Services Strategy. The basic rationale for this is that the Subscriber Services business is fully exploited under this strategy, and it is the Subscriber Services business which represents the ultimate profit-making opportunity. Note that three of the Mobile Messaging markets, namely the Message Center Software, Protocol Engines Software, and Device Software businesses, are linear returns businesses, and can therefore be expected to grow linearly.

The Subscriber Services market, however, is fundamentally different: it is an increasing returns business, and can therefore be expected to undergo exponential growth. It thus represents a huge business opportunity. Neda is seeking funding in order to execute Strategy III, and that is the purpose of this business plan.

We have presented the two alternatives largely to place things in perspective. We consider both alternatives to be inferior plan B's, and will execute them only if we do not acquire sufficient financing to execute Strategy III.

### **7.3.1 Timing**

Neda will execute Strategy III in two phases. Phase I consists of the implementation of the first half of our business model, i.e. the exposure of the LEAP assets, and the active promotion of the LEAP protocols. Neda has begun execution of this phase already, and expects this to take approximately 9 months to complete.

We have all the necessary technical expertise, managerial experience, and business infrastructure required to execute Phase I. We have nine years experience in the data communications industry, and we are fully confident in our ability to sell licenses and generate revenue. Therefore no external financing is required for Phase I; however, a relatively small amount of financing can serve to accelerate the Phase I schedule significantly. Neda can accommodate external financing of up to \$1.5 million for this purpose.

Phase II consists of the implementation of the second half of our business model, i.e. an aggressive campaign to dominate the Subscriber Services market. Neda expects to begin this phase as Phase I reaches completion, with about 3 months of overlap with Phase I.

Note that Phase I of our schedule is, in effect, Strategy I. Thus our intention is to begin with Strategy I, then make a transition to Strategy III. This approach has great flexibility. If the financing we need for Strategy III proves to be unavailable or delayed, we will simply continue with Strategy I. If we receive financing in a lesser amount than required to execute Strategy III, then we have the option of switching to the appropriate form of Strategy II.

Regardless of the amount and timing of financing we are able to secure, an appropriate strategy is available to us.

We have said previously that we believe our timing is perfect; that all the cultural and technological components are in place for the birth of the Mobile Messaging industry except one: an enabling set of protocols. However, we are well aware of the dangers of this perception; we know that history is littered with the corpses of those who thought their timing was right. We will guard against this danger by watching, waiting, then moving quickly when necessary. At the moment we are below everyone's radar, and can remain there indefinitely. However we have all the assets in place to be able to take rapid advantage of market opportunities as they arise.

### **7.3.2 Financing Options**

Neda requires \$15 million in financing to execute Phase II of its plans, at any point over the next 12 months.

In the interim, we have also put in place a well-defined and clearly structured investment framework, which will allow early investors to invest lesser amounts on favorable terms prior to our active fund-raising effort. Any investment proceeds acquired in this manner will be used to expedite and accelerate Phase I operations. Investors wishing to avail themselves of this opportunity should contact Neda directly.

## **7.4 The Target Investor**

This plan is being targeted towards a particular type of investor. The wireless data communications industry is exceedingly complex, from both a technical and a business point of view. Though we have tried to simplify and streamline our presentation as much as possible, there is a point beyond which we cannot simplify it; the plan therefore remains challenging technically and business-wise.

For this reason we are placing a burden of responsibility on the potential investor. It is important to us that prospective investors do their homework, by reading and understanding the public components of our business plan and other supporting materials. We have done our part by preparing these materials and making them available; we think it only fair to expect potential investors to do their part by reviewing them adequately before meeting with us.

This business plan is about leadership in a gigantic industry which revolves around a complex medium. Furthermore, the underlying technology is rapidly changing. For these reasons we are seeking a technically sophisticated and knowledgeable investor who can come to understand our premise quickly, with a minimum of educating on our part, and who can provide a complementary level of business expertise. We are actively looking for investors who in addition to capital can contribute to the management of the company.

To that end, we are reluctant to over-simplify the concepts, models and ideas expressed in this document beyond a certain point. If you are unfamiliar with some of the concepts and models presented here, you will find good introductory material in the References section. Also, please feel free to contact us with questions.

Involvement in business like this one is not for everyone. We believe in trust, long term relationships, patience and complete honesty. In addition, Neda has corporate values and principles that must be respected by any potential investor. First and foremost among these are:

- A commitment to the patent-free protocol model
- A commitment to the Open-Source Software model
- A commitment to the continued maintenance and enhancement of the LEAP protocols



We are only willing to work with investors and partners who share the same values.

#### **7.4.1 Investor Conflict of Interest**

An investor considering this business plan may find that he has a conflict of interest because of an existing investment position. For example, an investor in the wireless arena may already have an investment in a WAP-oriented company. Since this business plan is inherently anti-WAP, this may represent an investment conflict.

If there is any conflict of interest that prevents you from considering this investment opportunity, we ask you to advise us of this promptly. We will then immediately discontinue our discussions with you.

## **8 Phase I: Making LEAP Widespread**

We are framing our business strategy in the form of two phases of operation: Phase I and Phase II. The primary goal of Phase I is to make LEAP widespread; whereas the primary goal of Phase II is to capture the Subscriber Services market. Throughout each of these phases we indulge in the activities and approach the market segments which are most appropriate to these differing goals. We provide a description of Phase I in this section; Phase II is described in the Section 9.

It is important to note, however, that Phases I and II represent points on a continuum, rather than two entirely different modes of operation. There is not an abrupt discontinuity between Phases I and II; rather there is a smooth shift of emphasis as we make the transition between the two phases. Some Subscriber Services activity will take place during Phase I; and we will continue LEAP protocol and products development activity into Phase II.

Sections 8 and 9 therefore do not describe two different sets of activities. Both sections describe all the activities listed in the first column of Table 2; however, there is a radically different emphasis between the two sections. We are presenting our business strategy in the form of these two phases because there is a significant difference in the timing of the execution of each phase.

### **8.1 Key Ideas for Growth of LEAP**

Usage of LEAP is the crucial parameter that must be maximized during Phase I. During this phase we must focus on the primary goal of making LEAP widespread, and strategic relationships and partnerships are of far greater importance than generating licensing revenues and profits. The LEAP protocols will succeed and their usage will grow because:

- They meet the technical requirements of the industry.
- A set of protocols which do what LEAP does are desperately needed.
- There are no credible competing protocols.
- They are truly open and patent-free. Any company, organization, or individual may implement and use the protocols without incurring licensing or any other fees.
- Open-source implementations of the protocols are freely available in the form of open-source software.

Our patent-free protocols, free open-source software, and highly controversial articles will generate great interest in the wireless data communications industry, and will cause rapid adoption and propagation of the protocols. This will create incomparable mindshare and name-recognition for Neda, and will present us with similiary incomparable profit-making opportunities.

## 8.2 Three Virtual Business Units from the Start

Our business strategy calls for the simultaneous execution of activities in three significantly different arenas. In order to allow these different activities to proceed smoothly and in parallel, we are defining three distinct Business Units from the outset. During Phase I, the scale of our operations will be sufficiently small that these will not exist as formal operational divisions; rather, they merely refer to the different sets of activities that we will execute during this phase.

It is not until Phase II, when the scale of our activities will grow rapidly, that these different areas of activities will be formalized into distinct Business Units. From the beginning, however, we think of our activities as being partitioned as follows:

1. **The Protocols Business Unit.** This Business Unit will be responsible for (a) protocol development and promotion, by technical development of the protocols, and by promotion of the LEAP concept in the engineering and telecommunications community by distribution of the relevant documents, (b) propagation of the protocols by the development and distribution of free, open-source software, and (c) providing consulting services to support usage of the protocols.
2. **The Products Business Unit.** This Business Unit will be responsible for the development and sales of commercial software products for those market segments for which open-source software is not applicable.
3. **The Subscriber Services Business Unit.** This Business Unit will be responsible for the development of the Subscriber Services market.

Each of these Business Units will conduct its activities largely independently of the other two. Phase I will be dominated by activity within the Protocols Business Unit and the Products Business Unit; Phase II will be dominated by activity within the Subscriber Services Business Unit.

## 8.3 LEAP Protocols Business Unit

The primary purposes and goals of the LEAP Protocols Business Unit are to develop and maintain the LEAP protocol specifications, and to promote widespread usage of the protocols. This business unit will accomplish these goals by means of the following major activities:

- Protocol Development and Promotion
  - Technical development of the protocols
  - Promotion of the protocols by distribution of documentation and literature
- Propagation of the Protocols via Open-Source Software
  - Neda's software base
  - Neda's software licensing strategy
  - Neda's software distribution strategy
  - Protocol engines software packages
- Consulting

Each of these activities is described in the following sections.

### 8.3.1 Protocol Development and Promotion

Neda will initially play an active role in the development and maintenance of the LEAP protocols.

Technical development and maintenance of the LEAP protocols takes place via a set of public organizations. At present there are three of these: LeapForum.org, ESRO.org and EMSD.org, each of which has responsibility for a different aspect of maintenance of the LEAP family of protocols. All of these organizations are now up and running, and are fully operational.

During Phase I, Neda will play a major leadership role in the development and maintenance of the LEAP protocols via these organizations. During Phase II, however, Neda expects to relinquish this leadership role, and become just one of many people and organizations who work on the protocols in a democratic manner.

During Phase I, the Protocols Business Unit will also be responsible for making industry-wide exposure of all the assets we have created for the purpose of making LEAP widespread. We will publish and distribute the relevant documents (*The WAP Trap*, *The LEAP Manifesto* etc.), make all our software implementations available as open-source, and actively market message center software and systems licenses, and LEAP technology licenses.

### 8.3.2 Neda's Software Base

To build large multi-platform, scalable and industrial strength software, we need a solid development foundation. Figure 9 provides a high-level overview of Neda software components and architecture. The following major software components provide the foundation (consistency, portability, managability, scalability, ease of configuration etc.) for our products and services:

**Open C Platform (OCP):** OCP is an efficient virtualization layer that provides the basic support for all of Neda's developed products. OCP presently supports 8 distinct target platforms and a large number of development environments. OCP is freely and openly available, and is very well documented [?].

All of Neda's products use OCP and conform to its style and conventions.

To understand Neda's software development style, quality and philosophy, we recommend a review of OCP [?]. At Neda we take great pride in our work. OCP is free, open and publicly available. We invite interested readers to check it out.

**ESRO Protocol Engines:** The ESRO protocol engines are highly portable and are shared across a large number of platforms.

The ESRO protocol engines are based on OCP, are fully documented, and have been very extensively tested.

For additional information about the ESRO Protocol Engines, please refer to [?], [?], [?].

**EMSD Protocol Engines:** All of our EMSD products use the EMSD protocol engines. The EMSD protocol engines are highly portable and are shared across a large number of platforms.

All EMSD protocol engines are based on OCP, are fully documented, and are very extensively tested.

For additional information about the EMSD Protocol Engines, please refer to [?], [?], [?].

**Open-Source Message Center Architecture:** Over the years we have invested a great deal of time in the use of open-source software modules. In particular, we have made significant investments in the following large pieces of software: Qmail, Sendmail, Bind, IMAP C-Client, and Hylafax.

We have also invested greatly in Neda-developed utilities and tools that bring these individual software components under a consistent umbrella for administration, management, accounting and monitoring.

**Voice Response Development Environment (VoRDE):** VoRDE is the basis for all of Neda's Interactive Voice Response (IVR) systems and services.

For additional information about VoRDE, please refer to [?], [?].

For generic platforms, we will make the software available as free software through the <http://www.MailMeAnywhere.org/> software distribution center. The challenge here is to create a large virtual community of developers who use this software and further enhance it. On the device side, device software will be made available on most generic platforms including Palm OS, EPOC, Windows CE, Windows 9X, and Windows NT. On the Server side, software will be available on Solaris, Linux and NT.

In addition to generic platforms, we will also make the software available in various embedded environments.

### 8.3.3 Neda's Software Licensing Strategy

Almost all of Neda's software is available based on two sets of licenses:

1. Free Software Licenses
2. Neda Professional Software Licenses

Figure 10 provides an overview of how Neda's licenses apply to the various LEAP components.

Almost all of Neda's software is available as open-source through <http://www.mailmeanywhere.org/>. However this does not mean that Neda's open-source software can be used by all and in all environments. The GNU General Public License prohibits commercial use of the software and its integration with commercial software, and also prohibits its use in closed, embedded environments. For this reason, Neda also provides certain components of its software under "commercial" licenses, as described below.

#### Free Software Licensing

Neda's open-source software is usually subject to either the Gnu General Public License (GPL) or Gnu Library General Public License (LGPL) [?].

Neda chose GPL and LGPL as its free software licensing method after considering many other licensing models including: Mozilla Public License, Qt Free Edition, and BSD License. We chose GPL because of its track record, and because it is well understood and accepted within the software industry.

From a business perspective, the Gnu General Public License (GPL) is very restrictive. The GPL prohibits two commercially desirable activities:

1. The incorporation and mixing of LEAP with commercial software. The GPL demands that all code integrated with LEAP must also be free.
2. The incorporation of LEAP into closed systems. The GPL demands that the recipient of GPL software must be able to reproduce and modify any binaries that the recipient receives.

Because of these restrictions, there is a need for "commercial" licenses for the LEAP software, for those situations in which use of the GPL is inappropriate.

#### Neda Professional Software Licenses

In addition to the GPL and LGPL licenses, the LEAP software is also available under a set of commercial licenses, to accommodate those environments and usages in which the GPL is too restrictive. These licenses allow for commercial and non-free use of the LEAP software. Collectively, we refer to these licenses as "Neda Professional Software Licenses."

The Neda Professional Software Licenses are intended to address the following situations, among others:

- *Use of LEAP in closed systems.* When a mobile phone manufacturer or a modem manufacturer wishes to incorporate Neda's LEAP software, the Free and Open Source license that is publicly available is not adequate for this usage. The phone manufacturer will then need to license the exact same code from Neda under a Neda Professional Software License, instead of the GPL. For closed systems, by acting as the central commercial distribution point for the protocol engines, we can ensure the consistency and integrity of the the protocol implementations.
- *Integration of LEAP with non-free software.* For example, when a message center vendor (e.g. MS Exchange Group) wishes to integrate the LEAP protocols with its own software, it will need to obtain a Neda Professional License for the exact same free code that is publicly available.

### 8.3.4 Neda's Software Distribution Strategy

A key component of our strategy for making use of the LEAP protocols convenient and widespread is that we will provide free, open-source software implementations of the protocols, for all major segments of the Mobile Messaging industry.

On the device side, we will provide free, open-source software implementations of LEAP for all major device platforms, such as PalmPilot and Windows CE devices. Device implementations are already available for a large number of general-purpose device platforms.

On the Message Center side, we will provide free, open-source software implementations of LEAP which are fully integrated with major Message Center platforms such as Sendmail and Qmail. Message Center implementations are already available which have been integrated with Qmail and Sendmail.

In addition, binary formats of the software for a variety of platforms are available. In order to provide complete solutions, the LEAP protocol components are integrated with various other free software components, forming consistent and coherent bundles.

All this free and open-source software will be distributed through the MailMeAnywhere website. The MailMeAnywhere website is the general distribution center for all free and open-source software relating to the LEAP protocols. It is the major external operating and communications channel for the LEAP Protocols Business Unit.

For complete details, visit the MailMeAnywhere website at <http://www.MailMeAnywhere.org>. This website is already up and running, and fully operational.

The name "MailMeAnywhere" was chosen because the initial LEAP components are oriented towards interpersonal Mobile Messaging. One of the key ideas embodied in the LEAP protocols is that of "follow me mail," in which important mail messages can be forwarded to the mobile user, wherever he/she happens to be. The domain name "SendMailToMeWhereverIHappenToBe.org" is too long; hence the shorter and snappier MailMeAnwhere.org.

### 8.3.5 LEAP Protocol Engines Software Packages

When the LEAP protocol software is subjected to a Neda Professional License, we refer to the resulting product as a Protocol Engines Software Package. The protocol engines software market can be viewed as three distinct segments:

- Device Software Developers
- Message Center Software Developers
- Systems Integrators

Examples of Message Center Software Developers who are likely to be interested in deploying EMSD-based mobile messaging services are: Microsoft, Aldiscon, Evolving System, General Magic, Glenayre, Isocor, Lucent, Netscape, Sema Group UK, Sun Microsystems, Vertel, Wildfire, World Talk.

Examples of Systems Integrators who are likely to be interested in deploying EMSD-based mobile messaging services are: ISOTel, In Step, Data Critical, RadioMail, Telexon, Wynd.

Per sub-network source licenses for ESRO modules are priced at around \$15k. Per sub-network source licenses for EMSD device modules are priced at \$25k. The pricing for message center source licenses will begin at around \$80k.

We have already sold a number of EMSD and ESRO technology licenses. For a list of our recent licensees, see Appendix D.

### **8.3.6 Consulting Services**

Neda will also provide consulting services throughout Phase I of our plans. However, this will not be done with the primary goal of generating revenue; rather, the purpose of this is to support the fundamental Phase I goal of making LEAP widespread. Consulting services will be provided as necessary to support deployment and usage of LEAP in all three of the product-based market segments described previously (i.e. Protocol Engines Software, Device Software, and Message Center Software). Since the availability of consulting support will be of the greatest importance in the Protocol Engines Software market, the consulting side of our operations will be administered and managed under the Protocols Business Unit.

It is expected that in many cases, a consulting services contract will be bundled along with Protocol Engines Software Packages. This has typically been the case with previous sales of our Protocol Engines Software Packages.

Neda is already very experienced in providing consulting services; from 1991 through 1997, most of our revenue came from this source. We are experienced in negotiating and managing consulting contracts, and have a good track record of generating revenues from consulting services.

This business plan represents our plans for making a transition from being a consulting company, first to a product-based company (in Phase I), and then to a Subscriber Services company (in Phase II). For this reason the consulting side of our operations will be limited to the purpose and scope described above. Also, as LEAP becomes increasingly widespread during Phase I, the need for Neda to provide such consulting services will gradually diminish. We therefore expect that the consulting side of our operations will be increasingly curtailed as we move forward with our plans.

In line with our plans to become a LEAP product-based company during Phase I, we have turned down various consulting opportunities over the past two years. At this point we are only accepting consulting opportunities which closely match our product and business development goals.

## **8.4 LEAP Products Business Unit**

The primary purpose of the LEAP Products Business Unit is to promote and make widespread a variety of LEAP-based software products. During Phase I the goal is to encourage usage of the LEAP protocols; during Phase II the goal is to enhance and support the Subscriber Services Business Unit.

The external operating and communications channel for the LEAP Products Business Unit is the website Neda.com.

During Phase I, Neda will invest in, and derive revenue from, all four of the Mobile Messaging market segments described in Section 7.1. However, Neda will invest and derive revenues mostly from the LEAP Protocols & Technology market segment, specifically from sales of EMSD and ESRO technology licenses. Investment in the other segments will take place largely in preparation for Phase II.

At this point, all the software products necessary to execute Phase I of our plans are in place. However, we will continue to invest in the development of additional LEAP products throughout Phase I. But this will not be done with the primary goal of making profit; rather this will be done to support the fundamental Phase I goal of making LEAP widespread. Future products will be selected for development on the same basis as the existing products: we will develop products that best serve the purpose of promoting the widespread usage of LEAP, and which serve to integrate

LEAP into the larger interpersonal communications domain. Additional products will be developed as necessary to support deployment of LEAP in all three of the product-based market segments described previously.

Neda's existing software products consist of a large array which cater to all Mobile Messaging market segments. A complete list of Neda products is provided in Appendix C. All of these products are either available now, or will be available very shortly.

Neda's LEAP products fall into two categories, designed to address the requirements for:

- Message Center & Network Products
- Device Products

Each of these two sets of products is described below.

#### **8.4.1 Message Center & Network Products**

The EMSD Message Center Software and Systems market can be viewed as three distinct segments:

1. Public Operators (i.e. Wireless Network Operators, Paging Operators, and ISPs)
2. Private Operators (i.e. Corporate intranet messaging system operators)
3. Personal Desktop Messaging Users

This Message Center market breakdown is somewhat analogous to the different sorts of voice mail delivery systems that exist today. A large public service provider, typically the local telephone company, can operate your voice mail service for you. At work, a customer premise voice mail system may care of your voice mail. You can also buy a private and personal answering machine.

A similar set of options apply to mobile messaging Message Centers.

Neda produces Message Center products for each of the above market segments. In general, the products for each segment have their own specific requirements. The individual characteristics of the three market subsegments, and the corresponding product families, are summarized in Table 3.

#### **Public Operators**

The characteristics of the Public Operator subsegment of the Message Center product market are shown in the left column of Table 3.

The Message Center Software and Systems market for Public Operators can be viewed as 3 distinct customer bases with somewhat different cultures. Namely:

- Wireless Data Operators
- Paging Operators (AT&T, GTE, etc.)
- ISPs (UUNET, Netcom, PSI, etc.)

Examples of Wireless Data operator companies who are likely to be interested in deploying EMSD based mobile messaging services are: AWS, BCTel Mobility, Nextel, GTE, SNet, US West Wireless, Western Wireless.

	<b>PUBLIC (ISP)</b>	<b>PRIVATE (Corporate Intranet)</b>	<b>PERSONAL (Desktop)</b>
<b>Typical Customer</b>	Wireless Data Providers, Paging Operators, ISPs, etc. e.g. AT&T, GTE, PSI, UUNET, Netcom, etc.	Intranet Messaging Operators Fortune 5000 e.g. Boeing, Virginia Mason Hospital, etc.	Desktop Users e.g. YOU
<b>Product Description</b>	Message Center for ISPs, etc.	Message Center for Intranet	Personal Desktop Forwarders
<b>Platforms</b>	Solaris, Windows NT	Windows NT, Solaris, most other UNIX platforms	Windows NT/95/98, Solaris, most other UNIX platforms
<b>Key Attributes</b>	Manageability, Scalability, Reliability	Ease-of-use, Plug-and-play, Corporate Control	Ease-of-use, Plug-and-play, Personal Control
<b>Analogy</b>	Phone company provided voice mail (Octel, etc.)	Corporate provided voice mail (Active Voice, etc.)	Personal controlled voice mail (answering machine, etc.)
<b>Licensing</b>	- 500-pack user license - \$8 to \$25 per user	- 50-pack user license - \$100 to \$200 per user	- Personal user license - \$25 per user

Table 3: Message Center Market Subsegments



Examples of Paging operator companies who are likely to be interested in deploying EMSD based mobile messaging services are: American Paging, Metrocal.

Examples of ISP companies who are likely to be interested in deploying EMSD based mobile messaging services are: UUNET, Northwest Net, Northwest Nexus.

The key platforms for the ISP-Server-Agent product are: Solaris, Linux, Windows NT, and most other UNIX platforms.

Message center products targeted to public operators are designed with scalability and managability in mind. These products also support interfaces for accounting, provisioning, etc.

Neda produces large-scale LEAP-based message center modules which enable ISPs and Wireless Data Carriers to provide IP-based Mobile Messaging services to their existing subscribers. Neda's products are available both as software modules and as pre-configured subsystems. The software licensing structure consists of 500-pack user licenses. The target pricing on a per-user basis is between \$8.00 and \$25.00.

### **Private Operators (Corporate Intranet)**

The characteristics of the Private Operator subsegment of the Message Center product market are shown in the middle column of Table 3.

Such customer premise products give the Intranet message center operator full control over all aspects of the message center.

The key platforms for the Intranet-Server-Agent product are: Windows NT, Solaris, Linux, most other UNIX platforms.

Message Center products targeted to private operators are self contained and easy to install and operate. They need not be highly scalable.

Neda produces LEAP-based message center modules which enable Intranet operators of Fortune 1000 companies to operate their own customer premise IP-based Mobile Messaging services, as an adjunct to their existing e-mail servers. The software licensing structure consists of 50-pack user licenses. The target pricing on a per-user basis is between \$100 and \$200.

### **Personal Desktop Messaging Users**

The characteristics of the Personal Desktop Messaging User subsegment of the Message Center product market are shown in the right column of Table 3.

The personal desktop message center gives complete message center control to the individual end user. Neda produces personal IP-based Mobile Messaging rule-based forwarders, which operate under the user's control.

The key platforms for the Personal-Server-Agent product are: Windows NT, Windows 98/95, Linux, Solaris, and most other UNIX platforms.

Message Center products targeted to the personal operator are self-contained and very easy to install and operate.

### **8.4.2 Device Products**

Neda products and services can be used with a variety of wireless networks such as CDPD, GSM and Packet CDMA.

A summary of Neda's products for end-user devices is provided in Table 4. From a software licensing point of view, the end-user device software market breaks down into two subsegments:

	OPEN DEVICES			CLOSED DEVICES		
	Palm Pilot	WinCE	Other PDAs	Other Phones	Wireless Modems	Wireless PDAs
<b>Customer/User</b>	You	You	You	Nokia, Motorola	Sierra, Novatel	Palm, Qualcomm
<b>Typical Devices</b>	Palm V, Handspring	PalmPC	EPOC, Qualcomm	Nokia	Minstrel, AirCard 300	Palm VII
<b>Platform</b>	Palm OS	WinCE	EPOC	Closed	Closed	Closed
<b>Professional Licensing</b>	Shrink Wrap Neda Prof. Src.	Shrink Wrap Neda Prof. Src.	Shrink Wrap Neda Prof. Src.	Neda Prof. Src.	Neda Prof. Src.	Neda Prof. Src.
<b>Free Licensing</b>	GPL	GPL	GPL	None	None	None

Table 4: LEAP Device Software Products

- **Open Devices.** Examples of open devices are palmtop systems such as PDAs (Palm OS, Windows CE, EPOC, etc.). The key attribute of this segment is that the GPL license applies, so that this segment can be adequately served by open-source software.
- **Closed Devices.** Closed devices are those which have embedded software systems. This segment is best exemplified by the Modem Manufacturers. The key attribute of this segment is that the GPL license does not apply, and therefore a software product is required, licensed under a Neda professional license.

At this time, the three major handheld device platforms and palmtop operating systems for which EMSD protocols need to be available are:

- Palm Pilot
- Windows CE
- EPOC

In addition to these three, we will need to ensure that EMSD-based products are readily available for all other major open platforms.

Examples of palmtop software and hardware developer companies who are likely to be interested in deploying EMSD based mobile messaging services are: 3Com, Bsquare, Philips, Sharp.

Examples of Modem Manufacturer companies who are likely to be interested in deploying EMSD based mobile messaging services are: Airlink, Mitsubishi, Motorola, Novatel, Qualcomm, Rim, Samsung, Uniden.

## 8.5 Subscriber Services Business Unit

The eventual scope of our Subscriber Services business is extremely broad and ambitious. Our ultimate goal is to provide *all the computing and communication needs of the user, wired and wireless, fixed and mobile.*

The major development of the Subscriber Services business will take place in Phase II. However, we have already put in place an initial, simple, set of Subscriber Services, which integrate the LEAP protocols into a variety of other services.

At this time, all these initial Subscriber Services are generally available free of charge, and are intended primarily for demonstration purposes. Initially, these services will cater to the sophisticated mobile professional who wants to better understand the complexities of Mobility in the Internet through first hand experience. Neda's services also provide a test-bed for experimental services which can be used for test and validation purposes. These initial Subscriber Services will also support our goal of making use of the LEAP protocols convenient and widespread during Phase I.

During Phase I we are not prepared for and do not wish to address the scalability issues. Instead, we will focus our development efforts on the scope and comprehensiveness of the Subscriber Services. During Phase I we will keep the number of subscribers low, but we will prepare for rich expansion of our Subscriber Services and rapid growth during Phase II.

We are providing these initial free services through the domains ByName.net and ByNumber.net. These two domains are part of the same service; their separation into two domains merely reflects two different ways in which users can access the service. A complete description of the Subscriber Services Business Unit is provided in Section 9.2.

## 8.6 Phase I Marketing Plan

Our marketing plan for Phase I consists of three major components:

- An attack on WAP
- Talks and presentations at trade shows
- Hiring a professional Public Relations company to conduct a traditional technical marketing campaign

First, as discussed in Section 4.3, we will market LEAP in the form of a direct attack on WAP. We will begin this attack by making the two key documents, *The WAP Trap* and *LEAP: One Alternative to WAP*, widespread within the technical engineering community. We will do this by distributing these documents on the relevant mailing lists. At the time of writing, much of this has already been accomplished. We have already managed to generate general consensus in the engineering and technical community regarding the fraudulent nature of WAP and the need for an alternative to it.

Next, we will target these same documents to the key decision makers within the industry. We already have a list of key decision makers in our own in-house rolodex file; we will supplement this with further contacts from our business partners.

Finally, we will encourage press coverage of the WAP/LEAP controversy through professional Public Relations companies on a sustained basis. Note that press coverage of LEAP and Neda has already begun; for example see the articles *WAP Lash* [?] and *WAP 2.0: Mature Enough for Flight?* [?].

The second element of our marketing plan is that we will make a series of talks and presentations at the appropriate trade shows. The two most important trade shows in this regard are CTIA (Cellular & Telecommunications Industry Association) and EMA (Electronic Mail Association); we expect to make presentations at these and other relevant trade shows on a continuing basis. Neda personnel have already been frequent speakers at various conferences; for details refer to the “Presentations Made at Conferences and Trade Shows” section of the Neda website at <http://www.Neda.com>.

The third element of our marketing plan consists of a traditional technical marketing campaign, conducted by a professional Public Relations company. We already have relationships with two PR companies: BlueSky and pr.com; one or both of these companies is expected to manage our public relations requirements.

## 8.7 Phase I Goals

At a very high level, our goals for Phase I are:

- Aggressive & orchestrated promotion of LEAP
- Establishment of general, industry-wide awareness of LEAP
- Widespread distribution of LEAP protocols as free software
- Establishment of a highly scalable business structure

The key measure of our success prior to starting Phase II will be how successful we have been in making LEAP widespread.

## 8.8 Operation WhiteBerry

Our promotion of the LEAP protocols is supported by a comprehensive set of written assets. First and foremost among these is *The LEAP Manifesto*, a collection of 20 or so articles which describe every aspect of the LEAP protocols. Each article stands on its own as an expository document, and each can be played as a strategic card in our campaign to expose LEAP. We intend to distribute these articles widely within every segment of the wireless industry, including the

wireless telecommunications engineering community, the Internet engineering community, the business community, potential customers and strategic partners, the media, the academic community, and the investment community.

These articles and our other written materials will enable us to conduct a strong, coordinated and sustained campaign to promote the LEAP protocols at grass-roots level, complementary to the efforts of our external public relations company.

The strategic spearhead of this promotional campaign consists of the Manifesto article *Operation WhiteBerry* [?]. When we begin our public exposure of LEAP, this will be the first major article to be distributed. Based on the success and wide readership of our previous articles, we expect that Operation WhiteBerry will have been read by virtually the entire wireless industry within weeks of its initial distribution. Beyond a certain point, anyone who remains unaware of what Operation WhiteBerry has to say will simply look foolish.

In a single document, Operation WhiteBerry describes the heart of the entire LEAP premise. It describes in clear, concise and incontrovertible terms, how and why the LEAP protocols will form the basis for the creation of the open Mobile Messaging industry, and the enormous business opportunities that this will open up.

Operation WhiteBerry describes the **WhiteBerry** LEAP-based Mobile Messaging solution. WhiteBerry is a truly open messaging solution that provides equivalent functionality to existing closed messaging solutions such as the BlackBerry system. It is therefore destined to displace these closed solutions entirely.

But the most compelling aspect of the WhiteBerry model is that there is nothing remotely theoretical about it. It is an actual, concrete messaging solution that can be implemented immediately based entirely on existing open-source software implementations of the LEAP protocols, and other existing technologies. Any independent organization or industry alliance can create and market its own WhiteBerry solution *immediately*.

As a demonstration of this, we have created and fully documented our own implementation of the WhiteBerry solution, which any interested person can examine, duplicate, and verify. Therefore the WhiteBerry solution is not just an idea – it is an actual working system which is up and running today.

## 8.9 Phase I Financing

Neda is not actively seeking funding for Phase I. However, we have put in place a structure to allow us to accept funding during this phase. Any funding we receive during Phase I will allow us to accelerate the Phase I schedule, start on Phase II sooner, and help us to execute in a bigger way. We will need at most \$1.5 million during Phase I. Any Phase I funding proceeds will be used as follows:

- Recruitment

Our recruiting plans are described under the Phase II use of proceeds in Section 9.5.1. Any Phase I funding proceeds will be used to initiate the recruitment process as appropriate to the funding amount.

Initial recruitment efforts will be directed towards strengthening the Neda management team, including recruitment of qualified VPs of Marketing & Business Development, and a VP of Engineering or a General Manager. Initial recruitment efforts will also be directed towards expansion of the engineering team and the business development team.

A number of candidates have already been identified for management, engineering, and business development roles, who are expected to join Neda at the time of funding.

- Office Facilities And Equipment

In order to be ready for growth, we need larger office space and additional equipment.

- Public Relations

Our plans for the promotion of LEAP without funding are primarily engineering-oriented and based on the Internet grass-roots model. However, upon funding we will hire the public relations companies of pr.com and BlueSky to boost our promotional effort.

## **9 Phase II: Capturing the Subscriber Services Business**

We intend to begin execution of Phase II within 6 to 12 months from now. For this reason, the description of Phase II provided in this section is not detailed. Instead, we are providing only a broad overview of our Phase II strategy. Our intention is to give the reader a general sense of our strategy, and of its enormous financial upside.

Like all business plans, ours will change and evolve as the future unfolds, and the more distant parts of our plan will take on increased definition as their time draws near. We will be providing complete details of our Phase II strategy in subsequent revisions of our business plan.

We anticipate that organic growth of LEAP during Phase I will establish its presence on multiple wireless networks, on many device platforms, and on many message center platforms.

Our execution strategy for Phase II builds on the widespread availability of LEAP, and consists of an aggressive campaign to capture the Subscriber Services business. In this phase we actively promote and market LEAP as the dominant standard for Mobile and Wireless communications, and build the business infrastructure and assets required to dominate the Subscriber Services market.

### **9.1 Three Business Units from the Beginning**

Our strategy revolves around the creation of a protocol-based industry, and profiting from our leadership role in that industry by capturing center stage in the Wireless Application Service Provider (WASP) market. Therefore this is not just a Service Provider play; it is an Industry play. Execution of our plan requires continuous coordinated activities on at least three fronts: the LEAP Protocols, the LEAP Products, and the LEAP-based Subscriber Services. To this end, we will partition our activities among three Business Units from the outset.

As noted previously, during Phase I these units will not exist as formal operational structures; they will merely represent three distinct areas of activity. In Phase II, however, each of these units will take on a distinct individual identity. We will create three formal, independent Business Units for the management of each aspect of our operations.

#### **9.1.1 The LEAP Protocols Business Unit**

Details of the LEAP Protocols Business Unit operation were provided in the Phase I description in Section 8.3. The LEAP Protocols Business Unit will continue to operate during Phase II; however, its operational emphasis will change in certain respects.

First, it is expected that it will play a diminished role in terms of participation in the LEAP protocol development and maintenance organizations LeapForum.org, ESRO.org, and EMSD.org. As founder of these organizations, the LEAP Protocols Business Unit will play a dominant, leadership role during Phase I. Neda will certainly continue to play an active role in the LEAP protocol development process throughout Phase II and on into the future; however, as Phase II progresses Neda will relinquish its leadership role, and allow the essentially democratic nature of the maintenance organizations to take over.

Also, the significance of the revenue generating aspects of the LEAP Protocols Business Unit (i.e. sales of commercial licenses into the Protocol Engines Software Market) will gradually diminish. Its major purpose during Phase II will be to support the Subscriber Services Business Unit.

#### **9.1.2 The LEAP Products Business Unit**

Details of the LEAP Products Business Unit operation were provided in the Phase I description in Section 8.4. In Phase II the LEAP Products Business Unit will continue to operate in the same way; however, its significance as a

source of revenue will gradually diminish. Its major purpose during Phase II will be to support the Subscriber Services Business Unit.

In addition to our existing products, we will continue to develop additional LEAP software products in the future, for the continued purpose of promoting widespread usage of LEAP.

Our eventual plans go far beyond the Mobile Messaging application. The LEAP protocols and their implementation in the form of Mobile Messaging merely represent a tactical entry point into something much greater. They will get us started, but once things get moving and the big players begin to participate, we will then be ready to move quickly up the food chain.

One of our key areas of focus beyond Mobile Messaging is the **Integrated Customer Premise Message Center (ICPMC)**.

Our plans for the ICPMC are linked to our Subscriber Services strategy. We view our Subscriber Services as representing a new paradigm for how users meet their computing and communications needs. In this paradigm, the Subscriber Services represent a centralized core of very powerful and comprehensive computing and communications facilities. The user is then provided merely with an access system to these facilities.

This paradigm opens up several new models for how these services can be provided and distributed to users. One of these is the franchise model, in which the entire set of Subscriber Services is provided to a certain demographic by an independent service provider, under a franchise agreement. This is further discussed in Section 9.2.2 below.

The ICPMC is another model for distribution of services to users. The ICPMC is a method for providing Subscriber Services to a group of related users with a common set of needs, such as a fraternity, for example. The ICPMC consists of a local hardware/software system which acts as a “nearer point of presence” for the users, and with which the users interact directly. The ICPMC provides the users with high-speed services, and higher levels of autonomy and control. The ICPMC can provide information caching services, and can synch up with the main Subscriber Service system during off-peak times, improving the perceived speed by the user. The market for this type of system is expected to be extremely large.

The ICPMC can be considered the first stage of evolution towards an eventual “Integrated Network Appliance.” The ICPMC can also be thought of as a series of related message processing components, of which the LEAP components are a starting point. The types of additional features that will need to be provided by the ICPMC include Rule Based Message Processing, and Message Center Management Tools.

We have already made significant development investment in this direction, and can move quickly to exploit this market when the time is right.

### **9.1.3 The Subscriber Services Business Unit**

The purpose of the Subscriber Services Business Unit is to expand the user and subscriber base and capture eyeballs.

The external operating and communications channel for the Subscriber Services Business Unit will be the websites ByName.net and ByNumber.net. Free Subscriber Services will initially be provided through <http://www.ByName.net>.

In Phase II, the Subscriber Services Business Unit will become the dominant focus of activity, and all other activity will be subsidiary to, and in support of, the Subscriber Services business development.

Details of our Subscriber Services operations in Phase II are provided in the following section.

## **9.2 Neda’s Subscriber Services Model**

In this section we provide a description of the nature and characteristics of Neda’s Subscriber Services model. This represents our vision of the intended Subscriber Services from today’s perspective. What is described here is a general

framework, and many of the details described in this section are subject to change, and are expected to undergo significant evolutionary modification as we move forward with our plans.

### 9.2.1 Subscriber Services Up Front

A key element of our business model is that it revolves around Subscriber Services as its central purpose and goal. Though we are making an industry-wide play with our three Business Units, it is the Subscriber Services unit that is the essential point of focus for all three. In other words: *Subscriber Services must be placed up front.*

There are several reasons for this. First, there is much we can learn from history. Our model is based on the lessons we have learned from previous attempts to profit from developing protocol-based communications industries. Two examples are particularly instructive in this regard: Netscape, and Phone.com. Each of these represents a failed profit-making strategy.

In the case of Netscape, they initially put their Browser products up front, then later they put Server Side products up front. By the time they realized that Subscriber Services should be up front, and brought Netcenter to the foreground, it was already too late. The buy-out of Netscape by AOL demonstrates conclusively that Subscriber Services represents the top of the food-chain in the communications and computing industry.

The mistakes of Phone.Com are strikingly similar to those of Netscape. They have cornered themselves by placing Server Side products up front. More recently, they have also tried to position themselves as a Subscriber Services company. However, this places them in direct conflict with their partners and customers, and they remain stuck in this inherently untenable position.

The lesson to be learned is simple, and so is our strategy. We are placing Subscriber Services up front from the outset, and everything else, including our other Business Units, will be in support of Subscriber Services.

Second, it is the Subscriber Services business that represents the truly enormous Mobile Messaging opportunity. This is because, unlike other business opportunities, Subscriber Services is an increasing returns phenomenon, governed by virtual community laws that are not well understood at this time. But by virtue of its increasing returns characteristics, it can be expected to undergo exponential growth, and therefore represents an enormous profit-making opportunity.

### 9.2.2 Characteristics of Neda's Subscriber Services

The key characteristics of Neda's Subscriber Services are summarized in Figure 11. In the following sections we describe these characteristics in greater detail.

#### Largest Possible Audience

A very significant aspect of our Subscriber Services business is that it is targeted to the largest possible audience. As noted above, it is targeted to all demographics, all user devices, and all networks. It will include a globally-accessible telephone voice interface, which uses speech recognition, text-to-speech, and IVR in non-data (pure voice) environments on *all* phones. The Subscriber Services will be infinitely scalable to support unlimited audience expansion.

Throughout the following discussion, we draw a distinction between **users** of our Subscriber Services, and **subscribers**. Anyone is free to make use of Neda's Subscriber Services, without paying any fees, and without forming any kind of formal relationship with Neda. We refer to a person who uses our services on this generic basis as a **user**. A user need not provide Neda with any formal identification or personal information beyond that required to access the services, and there exists no fiducial relationship between the user and Neda beyond that of the customary Acceptable Use policy.

A **subscriber** is a person with whom there does exist some sort of fiducial relationship, implying certain obligations



on the part of both Neda and the subscriber. On the part of the subscriber, these obligations may include the payment of a service fee, and the disclosure of the subscriber's personal identity. On Neda's side, these obligations will include the protection of the subscriber's information and privacy, and guarantees of the quality of service.

For example, a subscriber may provide Neda with his/her credit card information, and will have the right to specify that he/she receive no unsolicited advertizing. A user, on the other hand, will typically not provide Neda with credit card information, and Neda will be under no obligation to shield a user from advertizing.

A good example of an existing Subscriber Service based on the user-type relationship model, as we have defined it, is provided by Yahoo. A good example of an existing Subscriber Service based on the subscriber-type relationship model is AOL. Our Subscriber Services will accommodate both types of relationship and usage model.

### **Personal and Customized Virtual Community**

Neda's Subscriber Services will take the form of a highly personal and ever-expanding virtual community. The services will be centered around interpersonal messaging using all appropriate media, including e-mail, voice-mail, Fax, etc. The services will provide users with a comprehensive suite of facilities and forums for interpersonal, communal, and social communications, such as: buddy lists, chat rooms, special interest groups, dating agencies, and multi-player games.

In addition, the Subscriber Services will provide users with various forms of information. This will include perishable information such as news, stock quotes, weather, sports, traffic, airline information etc., and non-perishable information such as white pages, yellow pages, dictionary lookup, etc.

### **Making it Widespread**

The Subscriber Services will include several characteristics designed to make their usage widespread. First, they will be provided to users free, and will be supported by advertising, content providers, etc.

Also, LEAP software implementations will be given away free, for all wireless data devices and environments.

Initially, our Subscriber Services will emphasize and focus on mobility, and the delivery of time-critical information. The opportunity to manage a user's mobility needs will provide us with frequent access to the user.

We will build a user base by paying carriers to bundle our services, and by sharing revenue with them. In addition, we will provide a cash and equity payment to carriers, providing them with a powerful incentive to open their networks.

One of the key ways in which we will expand our audience is by means of **franchise** operation. We view our Subscriber Services as a powerful core of computing and communications services which are accessed by users. There is nothing to prevent this entire set of Subscriber Services from being packaged and provided to an independent service provider, who then provides identical services to a particular demographic or subset of users.

For example, a third-world country might have only primitive and undeveloped Subscriber Services available to its consumers. An entrepreneur wishing to provide Neda's far superior Subscriber Services to this demographic could franchise the entire packaged set of Subscriber Services, then take responsibility for delivering them to this particular demographic. Note that the inherent hierarchy of the Internet and its domains provides an ideal structure for the creation and management of such franchises.

Clearly, this is an enormously powerful propagation and growth mechanism. Equally clearly, the financial rewards are enormous for the company that happens to be operating the franchise.

## **Completely Open & Free**

The Subscriber Services will be completely open and free; they will be based on open protocols, and implemented based on free software. In addition, the Subscriber Services will express preference for, and encourage usage of, free client and device software by subscribers and users.

This is an entirely new approach to the Subscriber Services business. The tremendous power of open protocols and free software has not been fully exploited by any other existing Subscriber Service. The primary beneficiary of the open-source software movement will be the Subscriber Service provider who understands and makes use of it to the fullest. Other service providers have a liability in terms of the assets that they have built.

## **User-Oriented**

The Subscriber Services will be oriented first and foremost to the needs and desires of the user, NOT those of the advertisers, content providers, or vendors. Nor will they be oriented to the benefit of Neda itself, the Subscriber Services provider and virtual community organizer. What this means is that the services will remain as passive, silent, and anonymous as the subscriber wishes. For example, if the subscriber wishes to see no advertising, he/she will see none. If the subscriber does not wish to be presented with unsolicited product and service offerings, then they will not be presented.

Because of our position as Subscriber Service providers and community organizers, during the process of building user and subscriber relationships, we will have access to user and subscriber usage information resulting from users' access activity and experiences. The gathering of such information is often referred to as "data mining," and is frequently used for targeted advertising. However, we will only use this method and model when the user or subscriber explicitly requests or authorizes this. As an element of our user-oriented role, we will use this information when acting on the subscriber's behalf as a Buyer's Agent in the "Infomediary" model [?].

Only when the subscriber explicitly requests product, service, vendor, or any other form of commercial information will it be presented to him/her. The subscriber may request such information on a one-time basis, in which case the system will then return to its former unobtrusiveness until called upon again. Or, the subscriber may authorize well-defined and qualified information to be presented to him/her on an on-going basis.

In either case, the Subscriber Services will act in the best interests of the subscriber. The services will make full use of the subscriber's information for this purpose, but will act as a guardian of this information, and will fully respect the subscriber's privacy.

### **9.2.3 Initial Subscriber Services: ByName.net & ByNumber.net**

Our initial, practical Subscriber Services implementation consists of two services: ByName.net, and ByNumber.net. As a starting point implementation, these initial services currently provide only a basic set of services to the mobile user. Eventually, the functionality of these services will be expanded to include the full range of capabilities listed in Figure 11.

As noted previously, some of the key characteristics of our Subscriber Services are that they are user-oriented, highly personalized, and show emphasis and respect for the user's identity above that of the service provider.

Our initial Subscriber Services implementation reflects all of these characteristics. The domain names ByName.net and ByNumber.net themselves reflect several of the characteristics of our Subscriber Services. First, they reflect their user-oriented nature. One of the aspects of our user-orientedness is that we are attentive to the needs of the user, but discreet – like a good butler. The names ByName and ByNumber reflect this self-effacing discretion: these names include no self-promotion of Neda whatsoever. Rather, the ByName and ByNumber services place primary emphasis on the user's identity; ByName is based on the user's name, while ByNumber is based on a numerical user ID.

The names ByName and ByNumber also reflect the very large intended scope of these services. Note that these

names imply no particular type of service (e.g. wired, wireless, fixed, mobile); therefore they imply *all* types of service. The ByName and ByNumber services also emphasize mobility for the user.

ByName provides a set of free services, based on free protocols which have been implemented as free software. The ByName service provides each user with his/her own personal domain, using a naming convention based on the user's name. For example, a certain well-known television celebrity might be provided with the domain:

```
homer.simpson.1.ByName.net
```

ByName thus includes the user's own name as part of the domain. The user can then use this single domain for all his communications needs. Homer can administer, manage and control his personal communications through his personal domain; and through this domain, ByName will provide Homer with a comprehensive set of Mobile Messaging, e-mail, personal web, and other open-ended services. The demand for these sorts of personal services is becoming more and more evident as the users of first-generation and conventional service providers become increasingly sophisticated.

By appending various selectors in front of the @ sign, Homer can be provided with a number of separate addresses and mailboxes, such as `personal@homer.simpson.1.ByName.net`, or `office@homer.simpson.1.ByName.net`. Other prefix selectors which Homer can use are: `urgent`, `public`, `mobile`, `pager`, `fax` and `emergency`.

This provides our anti-hero with a consistent set of e-mail boxes that he can use for different purposes – one address for personal mail, a different one for work-related mail, and so on. Homer now has control over the routing of his e-mail without having to use a mail sorter or filters.

The user's home page is also based on his name; Homer's is

```
http://homer.simpson.1.ByName.net
```

All of the above is in sharp contrast to the way Subscriber Services are being provided today. A conventional service provider typically provides the user with a single e-mail address, usually of the form "SomeName@SomeDomain.com," where the name "SomeDomain" serves to identify and promote the Service Provider. This provides the user with a single mailbox, to which all mail for that address is sent.

This becomes inconvenient when the owner uses the account for multiple types of incoming e-mail. For example, the user may use the account for both personal and work-related mail, to subscribe to various mailing lists, and to participate in usenet groups. Over time the user may get onto a large number of mailing lists, resulting in an incoming e-mail stream spanning a very wide dynamic range of importance, from urgent personal e-mail, all the way down to meaningless spam.

E-mail applications typically deal with this by providing the user with tools to manage and prioritize mail. These consist of inbox sorters and filters to eliminate spam and prioritize incoming messages based on the originator or subject.

The ByName.net service provides a better way. ByName provides the user with multiple mailboxes and addresses, each of which can be dedicated to a particular type of e-mail. These various addresses have a simple and uniform naming scheme, based on the one symbol that is most personal to the user: his own name.

To learn more about the ByName service and to apply for an account, see the website at <http://www.ByName.net>.

For more information on accessing Neda Personal Computing and Communications Services, see the subscriber access manual [?].

The ByNumber.net service provides a complementary service to ByName, based on numbers rather than letters. ByNumber enables devices with digit-only origination capability (e.g. conventional telephone keypads) to send e-mail messages, and provides a unified way of sending messages to pagers, two-way pagers, faxes and e-mail accounts.

ByNumber also includes a telephone voice interface which provides speech recognition, text-to-speech, and IVR capabilities on *all* phones. In this way the full functionality of our Subscriber Services will be made available through ByNumber, just as they are through ByName. The ByNumber service is primarily accessible through an Interactive Voice Response (IVR) system using a standard touchtone telephone. At present, ByNumber only supports user origination of messages by way of:

- One-Way Paging (e.g., numeric pagers, alpha-numeric pagers)
- Mobile Messaging (e.g., Enhanced Two-Way Paging (ETWP))
- E-mail (e.g., Internet E-mail, AT&T PocketNet Mail)
- Fax

However, ByNumber.net is intended eventually to become a full companion to ByName.net, for voice access.

You can access the ByNumber Interactive Voice Response (IVR) system by calling 425-644-2972.

To learn more about the ByNumber service, see the website at <http://www.ByNumber.net>.

To learn more about how the ByNumber service works, see the *ByNumber User's Guide* [?].

ByName.net and ByNumber.net provide the starting point for our Subscriber Services. We will build on this starting point, and eventually endow our services with all the characteristics listed in Figure 11.

Other service providers are rushing to expand their user base immediately and as fast as possible. However, our business strategy does not call for us to create a user base during Phase I, and we have no plans to begin building one at this time. We will not begin to create and expand our user base until well into Phase II. Until that time, we will instead focus on creating a comprehensive, reliable and rapidly scalable Subscriber Services infrastructure. We are confident that when the time comes, the uniqueness and power of our Subscriber Services model will be a compelling motivation for their widespread adoption.

### 9.3 Why Will We Succeed?

The scope of Neda's ambition is extremely large: we intend to become the equivalent of AOL and Yahoo for the wireless and mobile communications industry. Execution on such an ambitious scope and scale requires:

- Management leadership which is in tune with the medium
- Continuous growth and success of LEAP
- Aggressive financial backing
- Widespread partnership and business arrangements

These are necessary conditions for success; however, they are not sufficient. Even with all those conditions satisfied, two important questions remain. First, the Subscriber Services business is enormous – how can a small company like Neda succeed in capturing this business? Second, established Subscriber Services players such as AOL and Yahoo are already in existence. As newcomers, we clearly are at a disadvantage to these established companies. The fact that Subscriber Services is an inherently increasing returns business places latecomers at a further disadvantage. Why will Neda succeed as a small player in such a huge arena, a newcomer, and in competition with established providers such as AOL and Yahoo?

There are, in fact, three extremely good reasons why we will succeed in the face of these challenges. The first reason is that free and open protocols are an essential component of the Mobile Messaging industry. Any viable

Subscriber Services solution must be protocol-based, and nobody besides Neda has the necessary efficient protocols for the mobile and wireless environment.

Without such protocols, all efforts by existing virtual communities to expand into this environment will fail, because they will be closed solutions, they will be in competition with one another, and they will further segment the industry. Other companies who pursue this same goal, regardless of how much money they invest, will only create increased industry fragmentation because of their lack of a common set of protocols. The consumer needs and wants what Neda alone is providing: protocols as a basis for convergence.

The second reason is that, because of our Three Business Units, Neda will be a provider of **all three** of the key components required to make the Mobile Messaging industry work: protocols, products, *and* Subscriber Services. The existing players only have the assets to provide the final component.

(Of course, AOL or Yahoo can readily acquire the missing assets, either from Neda, or from a company that chooses to compete with Neda on this basis. However, these companies will be quick to recognize the advantages of in-house ownership of these assets. And an astute businessperson will soon recognize that the quickest and cheapest way to acquire the missing assets is to buy out the company that has the greatest investment in these assets – in other words, Neda.)

All that Neda has to do to make this a very real possibility is to become a credible threat to the existing Subscriber Services companies. For this reason, we view buy-out by a larger player is a very plausible and acceptable future scenario for Neda. And of course, this would provide a convenient and acceptable exit vehicle for our investors.)

Both of the above are compelling reasons for why we can compete and succeed in the Mobile Messaging arena. However, they say nothing about why we can succeed in the much broader Subscriber Services arena. For this we turn to our third reason for success: We represent the second generation of Subscriber Service providers, and can benefit from the experiences of our predecessors. Existing installed Subscriber Services evolved into their current model in an unplanned, ad hoc way. A Subscriber Services model designed from the ground up on the basis of the ad hoc blunders and errors of the past five years will have a significant advantage. In particular, history has shown the enormous power and importance of the completely free and open Subscriber Services model. Neda's services will be based entirely on free protocols and free, open-source software. Not only will the software implementations of the LEAP protocols be open-source, but in fact *the entire Subscriber Services software architecture* will consist of free software.

A new entry into the Subscriber Services business requires at a minimum (a) a new and compelling value proposition for the user, and (b) a method for wide and large scale exposure. LEAP qualifies and provides an entry point on both counts, and also brings the power of open and free into the equation.

Furthermore, our Subscriber Services will be designed to be franchisable and distributed. We will franchise the service by moving computing and communications services closer to the subscriber, and we will gain the trust of the subscriber by putting him in control of the service. Under this model free software is an asset, whereas commercial software is a liability. Also, the current assets, investments and commitments of existing Subscriber Services become a liability under this model.

This represents a radically new way of looking at, developing and maintaining software, and it has profound consequences. What this means is that the entire Internet engineering and technical community who devote themselves to working on open and free protocols and software have in effect become an extension of our own research and development division. The work of this army of talented and committed people can be integrated into our Subscriber Services on an ongoing basis. Our unique, groundbreaking ability to harness the extraordinary power of openness and freedom sets us apart from any other service provider, and represents a further compelling argument for our success.

Furthermore, our Subscriber Services model is based on the Internet end-to-end model. This model places the user squarely in the driver's seat. The user may choose the best access device and software based on competitive features such as performance, price, or whatever criteria are of most importance to the user.

Our Subscriber Services are thus structured in a radically different way to those of AOL and Yahoo. They are structured in a way which is enormously powerful, and which those other companies cannot realistically be expected to emulate. It is on this basis that Neda can enter and dominate the Subscriber Services business.

## 9.4 The Need for Financing

We have the basic technological assets required to make partial execution of Phase II. These assets consist of:

- An initial set of free subscriber services, which will form the foundation for our long-term subscriber services and virtual community building plans.
- Supported & Commercial Software & Solutions: message center and device software is ready and available for a variety of platforms.

On the basis of these assets, our expertise and experience, and our unique name recognition and first-mover advantages, Neda expects to profit very significantly from the success of the LEAP protocols and the growth of the Mobile Messaging industry.

However, the magnitude of the opportunity is so large that it is beyond our ability to take full advantage of it without external financing. The full potential of our LEAP-based, industry-building strategy cannot be realized unless a very large investment is made in Neda in the early stages of our Phase II operations.

Neda is in the process of creating a unique and extraordinary business opportunity. By means of external investment, the ability of Neda to profit from this opportunity will be increased enormously. We are seeking funding to *increase dramatically the scale of our success*. The appropriate level of investment will result in an enormous win for both Neda and the investor.

## 9.5 Phase II Use of Proceeds

The financing proceeds will initially be used:

- To recruit management personnel and strengthen the management team
- To recruit the staff necessary to support long-term growth under our marketing plan
- To improve our Customer Support services sufficiently to handle the increased demands created by the influx of new customers, users and subscribers
- To expand our marketing campaign to promote our protocols, standards and technology
- To develop strategic alliances with other key players in the industry
- To expand our business development and partnership efforts for promotion of our technology and products
- To increase sales by means of an extensive campaign to promote our products and services
- To increase R&D to create follow-on products as well as improve our competitive advantages

### 9.5.1 Recruitment

Neda understands that to execute its plans it will require the participation of skilled, experienced, and talented people. We also understand that recruiting the right people will be one of our most serious challenges. We therefore recognize that we will need to offer suitable incentives for people to make a commitment to Neda.

Part of this incentive, we believe, will come from the inherent uniqueness and excitement of what we are doing: we are building a gigantic new industry, on the basis of a bold new business model. This is a compelling story, and we expect it to be dramatic and dynamic in the execution.

In addition, we have a great deal of equity to motivate the participation of others: investors, employees, and business partners.

Also, Neda is well-connected in the data communications community. Among other things, we have maintained contact with a pool of talented people who have worked for Neda in the past, especially during the active consulting period of our company history. These people have knowledge of Neda and we of them, so a strong basis for a working relationship exists already.

For these reasons, we anticipate that we will have little difficulty in securing the enthusiastic and committed participation of talented personnel.

Our initial recruitment effort will be directed towards strengthening the Neda management team. Initially we will recruit qualified VPs of Marketing & Business Development, and a VP of Engineering or a General Manager. A number of candidates have already been selected and are likely to join Neda when funded.

In addition to the management team we also need to expand the engineering team and the business development team. In particular a number of candidates have been identified who are likely to join Neda upon funding. The list of candidates includes: Mark McWiggins, Derrell Lipman, Mike Marks, Murat Divringi, David I., Bob L., Andrew H., Garth D.

## **9.6 Risks and Competition**

Despite its huge upside, this venture is not without risk. In this section we describe the major risk factors. We also describe certain factors which we do not consider to be risks.

### **9.6.1 Non-Risk: Competing Protocols**

The foundation of all our plans are the LEAP protocols, and our entire business model is contingent on the success of these protocols. The appearance of a competing set of protocols, therefore, might be considered a risk factor.

However, we do not consider this to be a major risk. A public protocol is exactly that: public. The promotion of such a protocol is best served by making its existence known as early as possible, even in the earliest stages of its development. In this respect a protocol is very much unlike a product, whose existence or details may need to be kept secret until it is ready for market.

We are on all the relevant mailing lists where discussion of such a protocol would appear, and we can say with confidence that if any such protocol were in existence or under development, we would know about it.

Furthermore, even if development of a competing protocol were to begin immediately, it would take at least 18 months to achieve a workable first-draft protocol specification.

For these reasons we do not consider the appearance of a competing protocol to be a credible risk.

### **9.6.2 Non-Risk: Competing Software**

Part of our strategy for making LEAP widespread is the promotion and distribution of software implementations of the protocols, under both free and professional licenses. During Phase I, sales of professional licenses will also be a source of revenue for Neda.

There is nothing to prevent other companies from likewise developing and distributing LEAP software, also under either free or professional licenses. However, this is in no way a risk to Neda; on the contrary, this will be enormously to our benefit, since this will serve to accelerate the widespread adoption of LEAP.

The loss of revenue from sales of software licenses is trivial in comparison to this benefit.

### **9.6.3 Slight Risk: Shortsightedness of the Phone Companies**

The strength and effectiveness of the Mobile Messaging industry requires cooperation and understanding among several players, including mobile device manufacturers, wireless network operators, ISPs, and software providers.

Two of the key players are the telephone companies and the wireless network operators. We will refer to these two players collectively as the Telecommunications Industry. For largely historical reasons, the Telecommunications Industry tends to have a different culture and set of attitudes than the broader Data Communications Industry.

Most of today's closed wireless data networks are monopolies, or have their roots as monopolies. Also, the operation of these wireless networks is similar to the operation of phone companies. The type of fitness resulting from competition which the Data Communications and ISP market enjoys has been absent from today's wireless data networks. Many key technical decisions in the wireless data networks are likely to continue being made by unfit wireless data operators.

This represents a potential obstacle to the efficient development of Mobile Messaging, and to some extent can be expected to retard its development.

However, the power of the Internet end-to-end model and OSS will ultimately overwhelm all resistance. The trend towards open networks is clear, inevitable, and unstoppable; and any gatekeepers who resist this trend will eventually be eliminated.

Our challenge will be to form business partnerships with those companies who are quickest to understand, and act upon, the future of Mobile Messaging.

### **9.6.4 Major Risk: Inability to Execute**

The major, fundamental risk associated with this business plan is that of our inability to execute it. The scope of the plan is enormous, and calls for an extremely rapid growth rate on several fronts. This in turn calls for the creation of a highly sophisticated business structure, and for the management of a rapid and sustained scaling up of operations.

These are standard challenges in the high tech arena, and the business tools and techniques exist to address them. However, success in this depends upon having the right people for the task. To accomplish our goals, we will need a well-coordinated team of highly skilled and experienced management and technical personnel.

We have stated previously that we do not anticipate difficulty in recruiting talented personnel. However, the question is whether we will be able to recruit *sufficient* people, *sufficiently quickly*, to meet our goals. This is a very serious business challenge. Even with full financing and a skilled core management team, it may not be possible to do the necessary recruiting and team-building fast enough to sustain our growth rate.

However, the severity of this risk is greatly mitigated by the fact that, since we do not plan to begin executing Phase II for another 6 to 12 months, time is very much on our side. Assuming we receive near-term funding for Phase I, we will have adequate time to prepare for Phase II, do the necessary recruiting, and build the necessary business structures.

### **9.6.5 Major Risk: Competing Subscriber Services**

This risk is related to the previous one. In principle, there is nothing to prevent another company from competing directly with Neda on the basis of Subscriber Services.

Our competitive advantages in the face of this potential competition consist of our name recognition on the basis of the LEAP protocols and software, the fact that we provide all the components required to make Mobile Messaging work, our first mover advantage, and our fitness to move faster and with greater certainty than the competition. Since Subscriber Services is an increasing returns business, the first mover advantage is decisive; the company that begins to dominate this business will become increasingly dominant as time goes on.



However, the benefit of the first mover advantage depends on the ability of the first mover to capitalize on it quickly. If the first mover is unable to execute smoothly and rapidly, or otherwise blunders, this advantage can be lost. And there is no other advantage that Neda currently enjoys, that cannot eventually be eroded away by a competing company.

Therefore an inability to execute, coupled with aggressive competition on the basis of Subscriber Services, can prove fatal to Neda.

### **9.6.6 Major Risk: Timing**

Throughout this business plan, we have emphasized our belief that time is on our side. The rationale for this belief is that there are several basic trends at work in the wireless industry, and these will take time to develop fully. Three very significant trends are currently in progress:

1. Wireless data networks will converge on IP. Furthermore, native support for mobility will become an integral part of IP.
2. Operation of wireless data networks will move away from the telecommunications model, and towards the ISP model.
3. End devices (including phones) will move towards open platforms, such as Palm OS, EPOC, ECOS, Windows CE etc.

These trends are incontrovertible and inevitable, and they clearly point to the future wireless industry environment. In the near term we may very well see the deployment of various sorts of wireless application solutions which do not recognize this future reality. (WAP is a perfect example of this.) However, these will be short-term transient phenomena that will very soon be made irrelevant. They may temporarily confuse or obscure the above trends, but they will do nothing to stop them.

We have identified the eventual wireless industry landscape well in advance of the industry at large, and we have designed LEAP to fit perfectly into it. Therefore the significance and power of LEAP will become increasingly evident as the above trends materialize. At this point, however, we are still about 12 months away from general, industry-wide recognition of this future environment.

We believe that our thinking and vision are well ahead of those of the industry at large, and it will take time for the prevailing ideas and attitudes of the industry to catch up with us. Within the domain of free protocols, which are designed for efficient applications, and which satisfy the Internet end-to-end model, our free protocols and software are far ahead of anything that might be considered competition. Therefore it will take time for the significance of our protocols and software to become clear within the industry.

This is why we claim that time is on our side. And this is why we will not be seeking our major round of financing until 12 months from now; this is why we plan on spending the interim time executing our Phase I strategy; and this is why we believe that, if necessary, we can operate on a self-financed basis during this time.

In fact, at this point in the development of the industry, we believe that the danger of acting too soon exceeds the danger of acting too late. Indeed, thus far in the wireless industry, more people have lost by moving too soon, than by moving too late. In general, we believe that most wireless industry growth projections are overly optimistic in the short term. We agree that these growth projections will be realized eventually – just not as soon as the projections predict. Therefore we believe that the more realistic risk for Neda is that of acting too soon, rather than too late.

However, a major risk is that we could be entirely wrong about this. The time to act could in fact be now. By delaying, we could lose our window of opportunity entirely.

Our answer to this is that we stand by our current assessment. We have a deep understanding of the wireless data communications industry, and we continue to pay close attention to its trends and voices. On this basis, we maintain that our assessment of the current status of the industry, and our predictions for its future development, are correct.

Having said all this, however, if we begin to observe credible evidence that we need to speed up our plans, then we will do so.

## 9.7 Financial Projections

Detailed financial projections are provided on a separate set of spreadsheets. A description of the underlying assumptions on which the spreadsheets are based is also included with them.

The complete set of spreadsheets is very extensive and detailed. Here we are providing only the top-level Income Statement summary. Our intention is give the reader a sense of the enormous scale and upside of our business plans. The entire set of spreadsheets will be made available to qualified investors on request.

Financial projections are a traditional component of any business plan. And to satisfy this traditional expectation, we have taken the time to generate these sophisticated spreadsheet projections. These provide a useful analytical framework, and we use them as an effective thinking and planning tool on this basis.

However, to our way of thinking, the actual numerical projections have limited meaning. With or without projections, it is clear that the Mobile Messaging industry and Neda's opportunity are huge, and quantitative projections based on a set of arbitrary assumptions do little to clarify this – they merely present the illusion of clarification.

Furthermore, a key aspect of our business plan and revenue-generating model is that it is based on simultaneous execution within all three business units: Protocols, Products, and Subscriber Services. We know that there is an enormous amount of money in the Mobile Messaging industry *somewhere* – it is just not entirely clear where. On the basis of the best analysis that we can do from today's perspective, we think it is in the Subscriber Services business, and that is therefore what we emphasize in our financial projections. But we could be wrong about this. But since we will be actively and intimately involved in every fundamental aspect of the industry, we can readily shift our emphasis as necessary. We will closely observe the industry as it develops, and regardless of where the true money-making opportunity emerges, we will quickly adjust our strategy to take advantage of it.

This business plan is about building an industry. Our success in this is not going to be measured in terms of meeting specific financial goals. Rather, our success will be measured in terms of the widespread adoption of LEAP, our leadership role based on this, and our ability to exploit the resulting business opportunities in an agile, reactive manner.

### 9.7.1 Full Funding Financial Projections

As described earlier, Neda can execute its plans based on several different levels of funding. In this section we present a set of projections based on complete funding – i.e. Phase I funding of \$1.5 million immediately, followed by Phase II funding of \$15 million.

Figure 12 shows the top-level Income Statement summary for the next 5 years. The complete top-level summary also includes *pro forma* Balance Sheets, Sources & Uses Statement, Operating Statistics, and Pricing & Volume Projections. Only the Income Statement summary is provided here.

The income from each of the three Business Units is broken out separately in Figure 12.

#### Income from Subscriber Services Business Unit

The projected income from the Subscriber Services Business Unit is based on a simplified virtual usage model, rather than the more commonly used recurring subscription fee model.

One way to measure the revenue-generating “volume” of a Subscriber Services system is to base the measure on the number of users or subscribers to the system. Measures like this refer to the Subscriber Services volume in terms of “eyeballs,” or “eyeball capture,” where each eyeball represents a certain level of involvement on the part of a user. User

involvement includes such considerations as having the user’s attention, and having the opportunity to influence the user’s behavior. The revenues corresponding to this measure are then recurring revenues, such as monthly subscription fees.

An alternative way to measure revenue-generating volume is to base the measure on system activity – i.e. such measurable quantities as website hits, e-mail submissions & retrieval, etc. The revenues corresponding to this measure are non-recurring – there is a one-time revenue associated with each transaction.

Neither of these alone is an appropriate measure of revenue-generating volume for our purposes. Instead, we use a measure of volume which we call a **virtual usage unit**, and which incorporates both of the above ideas.

A **virtual usage unit** is a measure of system activity, representing a combination of website hits, e-mail submissions & retrieval, mobile messaging submission & deliveries, and voice access hits. However, we extend the notion of a virtual usage unit to include also the individual usage patterns of users and subscribers. The virtual usage unit thus includes measures of system usage *and* subscriber eyeball capture.

The annual projected Subscriber Services income is then based on two driving parameters:

1. The number of virtual usage units which occur during the subject year. This is shown in the “Number of Virtual Usage Units” row of Figure 12.
2. The revenue-generating value of each virtual usage unit. This is shown in the “Revenue per Virtual Usage Unit @ Year End” row of Figure 12.

The revenue-generating value of each virtual usage unit represents the totality of all revenue sources, including: advertising fees, subscription fees, content and information provider fees, and vendor charges (in those cases when we act as an Infomediary or Buyer’s Agent).

Note that the revenue-generating value of each virtual usage unit is not constant. Rather, it is a function of several things, including the current number of subscribers/users of the system. For this reason we show the value of this parameter at year end in Figure 12.

The total Subscriber Services revenue for each year is then the summation of the values of all the virtual usage units which occur throughout that year. This is shown in the “Subscriber/User Services Revenue” line of Figure 12.

Note that one of the key characteristics of the Subscriber Services business is that both the number of virtual usage units, and the value per virtual usage unit, increase rapidly as our services become widespread. It is this that accounts for the enormous growth of this revenue source.

Subscriber Services costs are also based on a non-recurring model. The costs associated with subscriber/user enrollment consist principally of cash paid to operators to give us access to their subscribers. These costs are shown in the “Cost of Subscriber/User Enrollments” line of Figure 12.

### **Income from LEAP Products Business Unit**

Neda’s product line and pricing structure were described in Section 8.4.1 and Section 8.4.2. The income projections shown in Figure 12 assume modest growth in volume. The primary purpose of this Business Unit is to support the Subscriber Services Business Unit; optimizing the income from the LEAP Products business is a secondary consideration.

### **Income from LEAP Protocols Business Unit**

Neda’s software packages, services and pricing structure were described in Section 8.3.5 and Section 8.3.6. The income projections shown in Figure 12 assume modest growth. The primary purpose of this Business Unit is to support

the Subscriber Services Business Unit; optimizing the income from the LEAP Protocols business is a secondary consideration.

## **Expenses**

The expenses for all three Business Units are lumped together in Figure 12. The dominance of the Sales and Marketing expense is almost entirely due to activity within the Subscriber Services Business Unit.

### **9.7.2 No Funding Financial Projections**

The above projections represent one extreme of funding for Neda, i.e. full funding. The other extreme is that Neda receive no funding at all. Under this scenario, Neda can execute the Protocol-Based strategy described in Section 7.2.1, but will be unable to execute the Subscriber Services strategy of Section 9.2. Neda will then remain a small, but highly profitable, technology and products company.

For our own purposes, we have prepared an alternative set of financial projections representing the scenario in which Neda is not funded at all, either for Phase I or for Phase II. Under this scenario, Neda will first become profitable within 15 to 18 months. These financial projections are not part of this business plan.

## **10 The Way Forward**

Throughout this business plan we have presented our vision of the future of the Mobile Messaging industry, and the role that we intend to play in it. At this point, we believe that we have presented our analysis in sufficient detail and clarity to allow a potential investor to decide where he/she stands.

It is now time for the investor to consider what we have said, and make a decision.

### **10.1 A Challenge to the Investor**

In many ways, this plan represents a radical departure from the traditional business model, and therefore presents a major challenge to the investor.

The creation of a business success story requires a number of essential and critical ingredients. Among these ingredients are a good idea, brought to realization by good engineering, the right people, and the right amount of capital. When all of these things are brought together in harmony, the results can be spectacular.

However, a perennial obstacle to this synergy is the fundamental conflict that may occur between engineering and business. These two constituencies embody very different value systems. The stereotypical engineer is driven by the desire to create things which are of enduring value to society. The stereotypical businessman is driven by the pursuit of financial profit. There is much truth in these stereotypes.

A further barrier to engineering/business cooperation is the extreme difficulty of comprehension and communication between these two constituencies. Each constituency has unique and valuable skills which are not properly understood, appreciated or respected by the other. This lack of respect stands in the way of synergy.

Two recent examples will illustrate these points very well. One example is the World Wide Web; the other is the Linux operating system. Both of these are engineering constructions; the underpinnings of the World Wide Web were designed by a group of physicists at the CERN laboratory in Switzerland, while Linux is the result of a distributed team effort by the Open-Source Software movement (though it is best known in association with the Finnish software programmer Linus Torvalds).

Both of these creations have now become phenomena of enormous technological and business significance. And because of this, both represented extraordinary business opportunities. In spite of this, however, neither project was treated as a business entity at the outset, and neither received any capital financing during its creation or early development.

What if the Web designers, or Linus Torvalds, had recognized the commercial significance of their creations, written a business plan, and teamed up with skilled businessmen and investors? The result would have been a spectacular tour de force for all concerned. Both engineers *and* businessmen would have reaped the classical rewards of engineering *and* business; together, they would have created something powerful, elegant and enduring, *and* made fortunes in the process.

In retrospect, all of this is abundantly obvious. So why didn't these engineers write business plans, join forces with venture capitalists, and reap the rewards? They didn't, because of the great gulf of misunderstanding and mistrust between engineering and business.

The engineers didn't write business plans for several reasons. First, it is quite likely that they did not fully recognize the enormous commercial significance of their own creations. Second, there would be little reason to expect that the VC community would fully understand the propagation mechanisms of these creations – in particular, the crucial importance of free protocols and open-source software. These are ideas which do not fit well with traditional business models. Finally, there is a trust issue – the engineers would have had well-founded doubts that any VC investor would fully support the open-source principles and mechanisms. Even if VCs had come aboard, would they have allowed the engineers to give full rein to the power of free protocols and open-source software, or would they have diverted this process by placing emphasis on short-term commercial and business goals?

On the other side of the table, the VCs would face a complementary set of difficulties to those of the engineers. The story that the engineers would have presented at that time would surely have seemed wildly improbable. Open and free web protocols? An open-source operating system? You have got to be kidding. How can you make money out of this? The idea is just too preposterous to take seriously. How many VCs could say with a straight face that they would have invested in Linux *before* it became widespread?

The VCs would have difficulty in recognizing the enormous technological significance of something like the Web or Linux. Furthermore, they would have difficulty in understanding the tremendous power of the Internet end-to-end model, free protocols, and open-source software. These are things which require a deep understanding of the medium, and are not easy to articulate. Linus Torvalds, and many others, *knew* what was going to happen with Linux. They knew this because they had spent years immersed in their medium, and they had developed deep insights into it. But it would not be an easy thing for the VCs to accept the technological predictions of the engineers.

Finally, the VCs would also have a trust issue – could the engineers be relied on to understand and respect the business imperatives – in particular, the need to create and sustain profits – or would they divert this process by placing emphasis on abstract engineering aesthetics?

For all these reasons, it is inconceivable that engineering and business could have gotten together to develop and profit from the Web or Linux in their early stages of development. The conceptual, communication and trust difficulties on both sides were just too problematic.

Nevertheless, both the World Wide Web and the Linux operating system represent colossal, staggering failures of the engineering and business worlds to join forces. The Web designers and Linus Torvalds did not write business plans, venture capitalists did not invest in the World Wide Web or Linux, and this incredible, once-in-lifetime opportunity simply rolled right past all of them. Fortunes certainly were made – just not by the originators, or the phantom VCs who might have financed them.

In a sense, this business plan is the execution of our side of the responsibility to see that this same colossal, staggering failure is not repeated in the case of the LEAP protocols. The enormous future that we claim for these protocols may seem wildly improbable to the business and VC community; however, we know that this future is real. We know this, because we have spent years immersed in our medium, and we have deep insights into it.

But unlike Linus Torvalds, we also know something more than this. We know that this future has gigantic com-

mercial potential. And we also know that its full potential cannot be realized without the committed participation of highly skilled business people, together with adequate VC backing. And we have a proper respect and understanding for the value that the business and VC world will bring to the table.

First and foremost, we are engineers, with engineering values and motivations. But we have taken a giant step out of the engineering world, and into the business world. We have recognized the commercial potential of our creation, and we have taken the trouble to articulate it to the business world in form of this business plan.

This is where our challenge ends, and the investor's begins.

At a certain point, the investor who chooses to invest in this opportunity will be required to make a leap of faith. Though we have tried to justify our vision in logical, deductive terms, part of our vision is the result of years of experience in the data communications field, and the very deep insight and understanding we have as a result of this. These are things that are not easy to articulate.

As an investor, your challenge will be to step out of your world, and into ours. Your challenge will be to recognize that there is something genuinely worthwhile in creating something powerful, enduring and beneficial, regardless of financial profit. And it will be to accept that we know what we are talking about, and we are right about what we say.

## 10.2 Distinguishing Between Hype and Substance

In addition to the above, there is another aspect of our business plan which presents a further challenge to the investor. The subject matter of this plan just happens to fall in the hottest and most frenzied area of business investment and speculation at the present time: *at the point of convergence of the Internet and the Wireless industries.*

This industry segment is characterized by an enormous amount of hype and hysteria. It represents the most extreme segment of the general Internet bubble, manifested in the form of bloated and unsustainable company valuations, and extreme stock price volatility.

Many talented entrepreneurs and investors are participating in this intense gold rush climate by backing and promoting companies based on hype rather than substance, and are making money as practitioners of the greater fool theory. The ultimate victim is the fool at the end of the line who will be left holding the bag. It is regrettable that such talented people have chosen to devote their efforts, and derive their rewards, from the redistribution, rather than the creation, of wealth.

The challenge this presents to investors is that, in the midst of this noisy and confusing environment, they must distinguish between those companies that have genuine substance, and those that are based on empty hype.

We hope that our protocols, our free software, our products, our track record, our reputation and our style will make it abundantly clear that our business plan is based on solid substance, not hype. All our assets are real and verifiable; all our claims are credible.

## 10.3 Knowing Your Values

At Neda Communications, Inc. our values are clear. We are firmly placed within the value system of the Internet technical and engineering community, and our primary motivations are to create something worthwhile and enduring. Our desire to make profit falls secondary to this, and what we are presenting here is not a get rich quick scheme.

For these reasons, we are not willing to sacrifice our commitments to the Internet end-to-end model, patent-free protocols, and the open-source software model, merely in order to get funding for our business plan.

However, it is precisely our commitments to these powerful principles that represent the enormous business potential of this plan. And our commitment to these principles is the result of our very deep understanding of our industry and our medium.

Because we have a clear understanding of our values, the way forward for us is also clear. We are focused on

making LEAP a success, and on building worthwhile and enduring things based on LEAP. If others are willing to participate in this and help us to increase our profits, then so much the better.

This is where our presentation ends, and where we turn responsibility over to the investor to consider his or her own values. What are your values – and are they consistent with ours?

At this point, as an investor, you have three choices. First, you can join us and move forward immediately. Second, you can decide to await further developments, and possibly get involved as a later-stage investor. Or third, you can decide to decline this opportunity altogether.

What is your decision?

Use	Protocol	Usage	Publication/ Availability	Open Source Implementation	Commercial Implementation	Development/ Maintenance	Standards Body Blessing	Long-term Success
Architecture	TCP/IP	Free	RFC / Open	Many	Many	Open	IETF (After)	Success
	SNA/DECnet	Licensed	Closed	None	Few	Closed	None	Fail
	ISO/OSI	Free	ISO/Limited	Few	Many	Limited	ISO	Fail
E-Mail	SMTP	Free	RFC / Open	Many	Many	Open	IETF (After)	Success
	X.400	Free	ITU/Limited	Few	Many	Limited	ITU	Fail
	MS-Mail CC-Mail	Licensed	Closed	None	Few	Closed	None	Fail
Security	S/MIME	Free	RFC / Open	Few	Few	Open	IETF	Fail
	PGP	Free	RFC / Open	Many	Few	Open	None	Success
WWW	HTTP/HTML	Free	RFC / Open	Many	Many	W3, Limited	None (W3 Later)	Success
 Wireless	LEAP	Free	RFC / Open	Many	Few	Open	None	?
	WAP	Licensed/ Patented	Self/Limited	Few	Few (More)	Limited (WAP Forum)	None	?

Figure 7: Protocol Success Stories



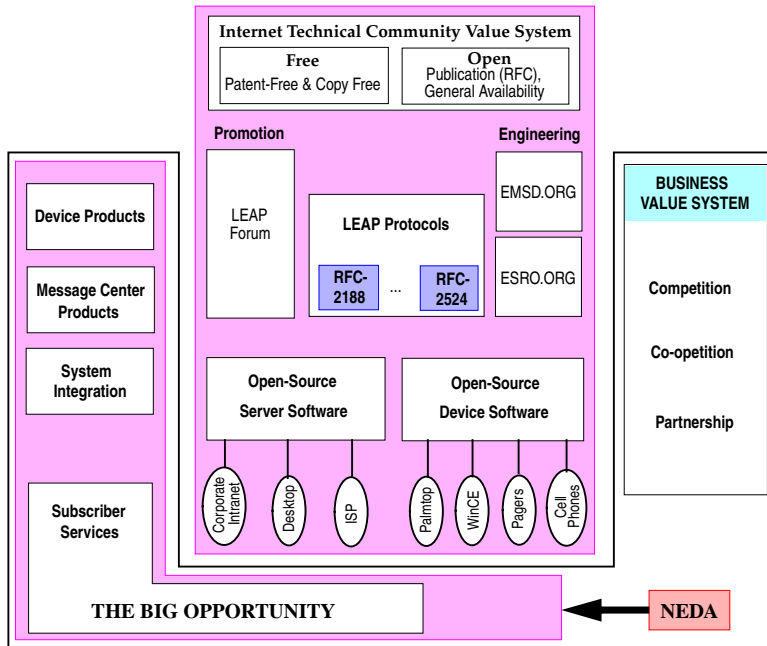

Figure 8: Protocol-Based Industry Building Blueprint

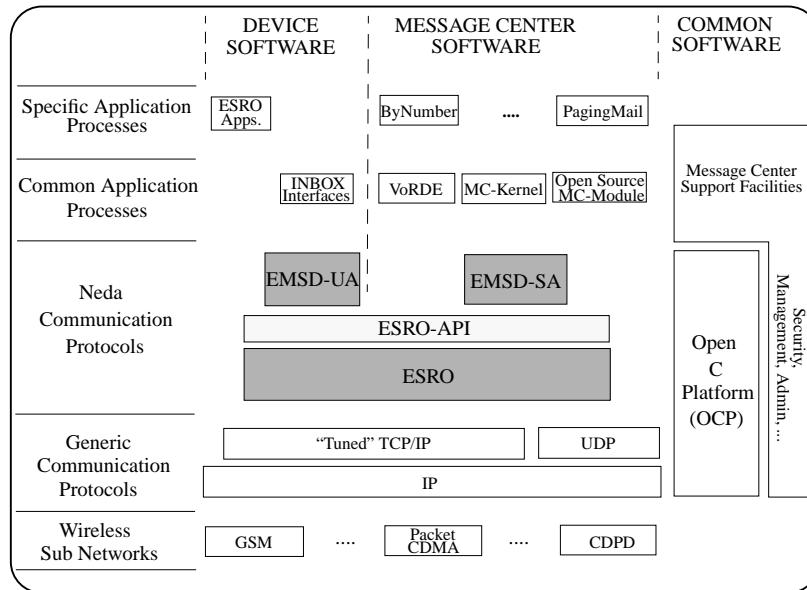

Figure 9: Neda Software Architecture

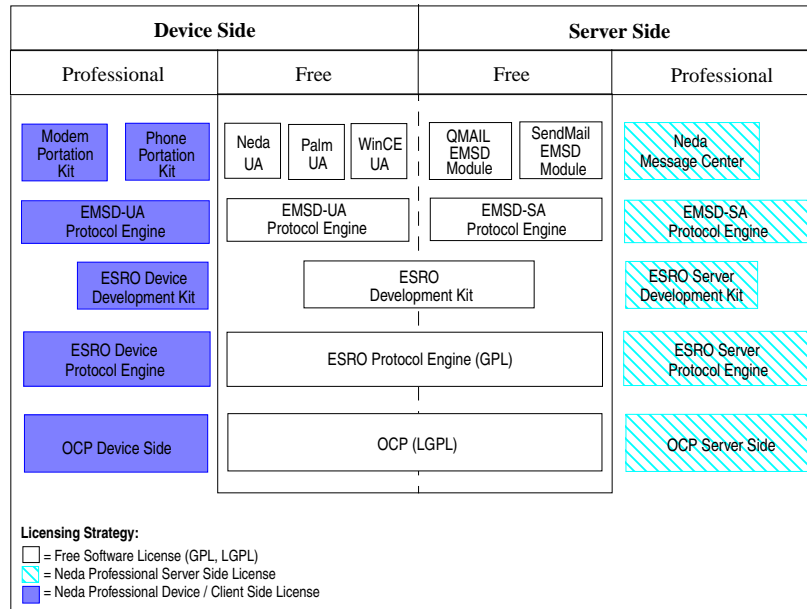

Figure 10: Neda's Licensing Strategy

---

- **Largest possible audience**

- All demographics (mobile professionals, soccer moms, teenagers, etc.)
- All devices (phones, PDAs, laptops, desktops)
- All networks (Internet, GSM, CDPD, iDEN, etc.)
- Powerful, globally-accessible, telephone voice interface
- Infinitely scalable
- Fully exploits Internet & domain hierarchy
- Highly distributable, designatable & franchisable

- **Personal and customized virtual community**

- Oriented towards interpersonal messaging: e-mail, voice-mail, Fax, etc.
- Buddy list, chat, special interest groups, dating, multi-player games
- News, stock quotes, weather, sports, traffic, airline information
- White pages, yellow pages
- E-commerce

- **Making it widespread**

- Make it free (supported by advertising, content provider, etc.)
- Give away LEAP for all wireless data devices and environments
- Leadership of LEAP will give us the attention we need
- Emphasize, encourage and enable mobility, urgency and frequent usage
- Build user base by paying carriers to bundle our services

- **Completely open & free**

- Based on truly open protocols
- Implemented based on free and open-source software
- Preference for, and encouragement of usage of, free client and device software by subscribers and users

- **User oriented**

- An agent of the subscriber
- A guardian of the user's information
- Full respect for the user's privacy
- A facilitator – not the owner of information
- A Buyer's Agent for the user – an Infomediary model

---

Figure 11: Neda's Subscriber Services at a Glance

<b>Neda Communications, Inc.</b>					
<b>Pro Forma Income Statement: YEAR 0 - YEAR 4 (\$)</b>					
	YEAR 0	YEAR 1	YEAR 2	YEAR 3	YEAR 4
	(6 months)				
<b>TOTAL REVENUE</b>	\$628,333	\$42,741,667	\$216,114,530	\$1,191,585,158	\$2,370,568,025
<b>Subscriber Services Business Unit:</b>					
Number of Virtual Usage Units	30,000	1,500,000	4,000,000	14,000,000	24,000,000
Revenue per Virtual Usage Unit @ Year End	\$5.00	\$30.00	\$65.00	\$95.00	\$101.00
Subscriber/User Services Revenue	\$108,333	\$33,541,667	\$202,414,530	\$1,178,560,158	\$2,360,218,025
Cost of Subscriber/User Enrollments	\$504,167	\$39,270,833	\$161,207,265	\$799,280,079	\$1,540,109,012
<b>Profit from Subscriber Services Business Unit</b>	<b>(\$395,833)</b>	<b>(\$5,729,167)</b>	<b>\$41,207,265</b>	<b>\$379,280,079</b>	<b>\$820,109,012</b>
<b>LEAP Products Business Unit:</b>					
ISP Product Licenses	\$150,000	\$4,000,000	\$5,000,000	\$5,000,000	\$5,000,000
Intranet & Device Product Licenses	\$100,000	\$2,500,000	\$6,000,000	\$6,000,000	\$4,000,000
<b>Profit from LEAP Products Business Unit</b>	<b>\$250,000</b>	<b>\$6,500,000</b>	<b>\$11,000,000</b>	<b>\$11,000,000</b>	<b>\$9,000,000</b>
<b>LEAP Protocols Business Unit:</b>					
Technology Licenses	\$240,000	\$2,000,000	\$2,000,000	\$1,500,000	\$1,000,000
Technical Support Services	\$30,000	\$700,000	\$700,000	\$525,000	\$350,000
<b>Profit from LEAP Protocols Business Unit</b>	<b>\$270,000</b>	<b>\$2,700,000</b>	<b>\$2,700,000</b>	<b>\$2,025,000</b>	<b>\$1,350,000</b>
<b>GROSS PROFIT</b>	<b>\$124,167</b>	<b>\$3,470,833</b>	<b>\$54,907,265</b>	<b>\$392,305,079</b>	<b>\$830,459,012</b>
<b>EXPENSES</b>					
R & D and Engineering	\$781,978	\$5,276,951	\$14,253,988	\$36,149,114	\$77,040,386
Sales and Marketing	\$567,747	\$10,244,517	\$31,193,818	\$116,031,985	\$235,695,950
Finance and Admin	\$479,742	\$1,311,673	\$1,977,321	\$3,487,122	\$6,248,650
<b>TOTAL EXPENSES</b>	<b>\$1,829,467</b>	<b>\$16,833,141</b>	<b>\$47,425,126</b>	<b>\$155,668,220</b>	<b>\$318,984,987</b>
<b>NET INCOME before Income Tax</b>	<b>(\$1,705,300)</b>	<b>(\$13,362,308)</b>	<b>\$7,482,139</b>	<b>\$236,636,859</b>	<b>\$511,474,026</b>

Figure 12: Full Funding Financial Projections

## **A Neda Team Biographies**

### **A.1 Principals**

#### **A.1.1 Mohsen Banan, President, Neda Communications, Inc.**

Mohsen Banan is a recognized expert in the design and implementation of distributed systems, especially message handling and mobile data networks. He is particularly well-known for his expertise in data communications, telecommunications and wireless protocols.

Mr. Banan's career in data communications and Unix began in the early 1980s. He was one of the seven software engineers who developed Retix's core technology in 1986. Prior to 1991 he worked as an engineer and manager for nine different companies, including Teknekron, InterConnections, Cellular Technical Services and Boeing. Mr. Banan founded Neda in 1991 and has been its President up to the present.

From 1992 to 1995 Mr. Banan led the technical network architecture design for the Cellular Digital Packet Data (CDPD) specifications. He played a key role in the formation and direction of the CDPD industry. He was also directly involved in many aspects of the planning, development and deployment of the CDPD network services.

Mr. Banan has a large body of publications. His recent publications include RFC-2524, RFC-2188, The LEAP Manifesto, and Internetwork Mobility, published by Prentice-Hall.

Mr. Banan is also responsible for a large amount of Open-Source and free software, most of which is in the form of highly portable and efficient protocol engine implementations. He has 20 years of experience encompassing all major aspects of Unix: device drivers, systems programming, systems administration, application programming and user interfaces.

Mr. Banan has a long track record of participation in standards related activities. Over the years he has participated in various activities of NIST-OIW and CTIA, and he is an active participant in various IETF activities. He is also the founder of the Free Protocols Foundation.

Mr. Banan's latest crusade is to make the Lightweight & Efficient Application Protocols (LEAP) widespread and the mainstay of the industry. His combination of technical expertise, visionary thinking and business experience makes Mr. Banan a unique asset to such an ambitious industry-building venture.

Mr. Banan holds a BS degree in Electrical Engineering (Magna Cum Laude) from Seattle University and an MS degree in Computer Engineering from the University of Washington.

#### **A.1.2 Pean Lim, Principal Engineer**

Pean Lim has substantial experience in the design, implementation and deployment of network computing applications, particularly in the domains of systems and network management. Prior to his current position at Neda Communications, Inc., Mr. Lim was a Principal Software Engineer at Digital Equipment Corporation, where he played a key role in the proposal, concept-proving, design and implementation of the Digital UNIX Performance Manager based on SNMP technology. Mr. Lim has also been involved in the design and development of several other network management systems based on X11, SNMP, RDBMSes, C and C++ technologies.

Mr. Lim's career began in the mid 1980s in the area of expert systems and knowledge representation with a series of internships at Xerox Palo Alto Research Center (PARC), where he developed object-oriented systems in Smalltalk and Loops. He went on to join the Research and Advanced Development group of Teknowledge, Inc., one of the first expert systems software companies. At Teknowledge Mr. Lim helped develop ABE, a system for graphically constructing distributed, migratable applications running on a network of SUN workstations and Symbolics Lisp Machines.

Mr. Lim is recognized as, and takes pride in being, a hands-on Software Systems Engineer. He has significant expertise and interest in the areas of TCP/IP, RDBMSes, and object-oriented systems and languages. Mr. Lim's

Master's thesis work on Plan Management was done at Xerox PARC. He holds BS and MS degrees in Computer Science, and a BS in Civil Engineering, all from the Massachusetts Institute of Technology.

### **A.1.3 John Urrutia, CFO, Neda Communications, Inc.**

John Urrutia is responsible for Neda's accounting procedures, financial reporting, tax strategy & compliance, and business planning. He is also responsible for preparing the company for venture capital financing and an initial public stock offering. John consulted independently to Neda from 1995 to 1998, then joined the Neda team as CFO in 1999.

Mr. Urrutia has 12 years experience in helping companies to improve their profitability, manage risk, and develop tax plans & financial reporting goals. He advises senior financial managers & business owners, plans strategic tax & business decisions, and automates financial accounting systems. Besides advising telecommunications & technology professionals, John also consults with a variety of individuals and business owners in financial securities, real estate, wholesale and retail product & service, commercial fishing, manufacturing, insurance & professional services.

His CPA firm's revenues & net profit have increased over 11 consecutive years. He has recruited, trained and mentored staff for greater efficiency and enhanced client services. His client service goals include minimizing clients' tax liability and maximizing their financial position by assertively structuring business facts, circumstances & tax planning strategies to support Federal and State tax savings.

Mr. Urrutia received a scholarship and earned an Entrepreneur's Certificate from Dartmouth College, Hanover, NH in 1994. In 1993 he earned a Masters of Science in Taxation from the Golden Gate University, Seattle, WA. He is a Renton Technical College business school advisory board member, and a member of the American Institute, the Washington Society of CPAs, and the Institute of Management Accountants.

### **A.1.4 Andrew Hammoude, Consultant**

Dr. Andrew Hammoude has over 26 years experience as an engineer, including both academic and industrial experience. In the academic setting this includes research and extensive teaching, and in industry this experience includes engineering design, project management, consulting, and entrepreneurship.

Dr. Hammoude has a Ph.D. in Electrical Engineering from the University of Washington, a Master's in Electrical Engineering from the University of Toronto, and an undergraduate degree in Engineering from the University of Cambridge.

His Master's research project was in the area of systems and controls; he developed a system for the real-time adaptive control of a mineral ore processing plant, and implemented it at a working zinc mine in Quebec, Canada. His doctoral research project was in the area of image processing; he designed and implemented a hardware/software system for the computer analysis of medical ultrasound images. He also designed and implemented a system for automatic endocardial border identification in echocardiographic images.

Dr. Hammoude's involvement in Neda Communications, Inc. is his second participation in a high-tech entrepreneurial venture. In 1988 he became co-owner of IMAGEsystems, Inc., a high-technology start-up company involved in the development of advanced image processing hardware and software products. He joined this company at a very early stage, and was involved in virtually all aspects of the start-up. He created the company Business Plan: he did the necessary market research, defined target markets, established sales and marketing strategies, established a product development plan, determined a staffing and recruitment schedule, and developed detailed financial projections. He also produced all company written materials, including technical manuals, sales and marketing literature, and press releases. He also took initial responsibility for all sales related activities, and secured the first company sales.

Since 1991 he has provided engineering consulting services, both to IMAGEsystems and to several other clients. These consulting services have included systems analysis services, project management services, and the creation of technical engineering documentation for a variety of projects.

Dr. Hammoude has been with Neda Communications, Inc. since December 1999. His broad academic and industrial background in Electrical Engineering, entrepreneurial experience, and superlative writing skills make him an ideal fit for the current needs of Neda Communications, Inc. His principal responsibility is to create all written materials necessary to communicate the company's philosophy, goals, and strategies to clients, business partners, and investors.

## **A.2 Advisors**

### **A.2.1 Joseph J. Pruskowski, Advisor**

Joe Pruskowski is an accomplished executive and entrepreneur with over 18 years experience in the computer industry. His list of successes include co-founding two networking companies and serving as Vice President of a public company. Mr. Pruskowski is also active in the investment community, lending his expertise in the area of mergers and acquisitions.

Mr. Pruskowski currently consults to a number of clients in the computer industry in the areas of business development, strategy, partnering, M&A, and technology development.

In 1996, Mr. Pruskowski was the founding CEO of CacheFlow Inc., a venture-backed provider of Web caching appliances. He was responsible for the initial business planning and fund raising, which culminated in over \$14M of investment including both private and venture capital funding. In late 1997, CacheFlow's headquarters were moved from Washington to California, and Mr. Pruskowski elected to remain in Washington and pursue his consulting business.

From 1994 through 1996 Mr. Pruskowski was an independent consultant in the areas of business and technical development. His area of expertise was in the networking segment of the computer industry. He provided consulting services for M&A endeavors, including due diligence, company partnering, and planning.

From 1991 through 1994, Mr. Pruskowski served as VP, Software Development and Chief Technical Officer (1994) of EMULEX Corporation. In these capacities, he was responsible for technical strategy, product direction, and strategic partnering.

In 1987 Mr. Pruskowski co-founded InterConnections, Inc., a provider of networking software that connected minicomputers with PC LANs. As the founding VP of Engineering, he was responsible for both product development and company strategy. In 1990 he was promoted to CEO, and was chiefly responsible for the acquisition of InterConnections by EMULEX Corporation in 1991.

From 1979 to 1987, Mr. Pruskowski held technical and management positions at various companies, including Sandia National Labs and Digital Equipment Corporation.

Mr. Pruskowski studied Computer Science at the University of New Mexico (1982).

### **A.2.2 Murat Divringi, Advisor**

Murat Divringi has been actively involved in designing, developing and delivering commercial software products since the early 1980s. He has led the development of products that are installed in thousands of sites throughout the world, many of which are at Fortune 500 companies, performing mission critical tasks.

Before joining Neda Communications, Inc., Mr. Divringi was the Director of Engineering at Emulex Network Systems' Northwest Development Center, where he was responsible for the design and implementation of several product lines. During the last two years of his tenure, Mr. Divringi managed the technical development of the company's entry into the Remote Access Server marketplace, creating a competitive product in less than one year, from conception to First Customer Ship. The product (ConnectPlus LT) has since been described as "innovative," "easiest to use" and "best buy" by industry trade magazines, and has shipped several thousand units within its first



year.

Prior to Emulex Corporation, Mr. Divringi worked with InterConnections, Inc. as the Technical Program Manager and Product Line Architect for the company's Novell NetWare value-added product line on VMS, Unix, NetWare, LanManager and MS-DOS/Windows platforms. At that time, InterConnections was a pioneer in providing VAX/VMS based file servers and terminal session transport technologies to the industry. Mr. Divringi performed the necessary technical marketing and feasibility research, and designed and led the implementation and launch of several successful network connectivity products. Mr. Divringi also attended and presented sessions at various conferences, conducted interviews with end users and system integrators, and modified product design, packaging and licensing strategies as needed to better serve the customers' needs.

At Neda Communications, Inc., Mr. Divringi's focus is on the formation of Neda's various messaging product strategies, ranging from developer toolkits to turnkey messaging servers. Mr. Divringi has an M.S. degree in Computer Science, specializing in Systems Design, from Rensselaer Polytechnic Institute. He also holds a B.S. degree in Industrial Engineering from Bosphorus University of Istanbul, Turkey.

## **A.3 Associates**

### **A.3.1 Mark McWiggins, Associate**

Mark McWiggins has over 21 years experience in the computing industry. His areas of expertise include electronic mail systems, computer language design and implementation, relational database internals, and web e-commerce systems.

Mr. McWiggins is the proprietor of Hermes and Associates, a Seattle-area consulting firm which has been in existence since 1993. Besides Neda Communications, Hermes' clients include Real Networks, Amazon.com, Siemens Ultrasound, and many others. In 1994 he worked with Spry, Inc. and developed the infrastructure for an early online store ([www.booksonline.com](http://www.booksonline.com)).

Previously, Mr. McWiggins spent 1987 through 1990 at Integration Technologies (Intek), a Bellevue company specializing in the automation of warehouses and manufacturing facilities, where he developed database and computer language technology that even today remains fundamental to the success of that business. From 1979 until 1983 he worked for IMSL, Inc., a Houston purveyor of mathematical software.

Mr. McWiggins' latest project is Printcop, an open-source system for printer accounting and authentication. He received a B.S. degree in Computer Science from Louisiana State University, with honors.

## **A.4 Technical Staff**

### **A.4.1 Pinneke Tjandana, Technical Staff, Neda Communications, Inc.**

Ms. Pinneke Tjandana received her B.S. degree in Electrical Engineering from the University of Washington in 1997. Her areas of specialization are in communications and Digital Signal Processing (DSP). She began her career at Neda Communications, Inc. in February 1998.

Ms. Tjandana's responsibilities at Neda Communications, Inc. include:

- Analyze the user requirements for Neda's Enhanced Two-Way-Paging for Windows CE handheld PCs (Neda-ETWP-wce)
- Analyze the performance of Neda-ETWP-wce, and incorporate new features as necessary to satisfy additional user requirements
- Evaluate and implement enhancements to the User Guide for Neda-ETWP-wce and its relevant data sheets

- Provide assistance and support to Neda customers in the deployment of Customer Premise Two-Way-Paging Message Center software, and in the use of Neda-ETWP-wce

#### **A.4.2 Arghavan Banan, Technical Staff, Neda Communications, Inc.**

Ms. Arghavan Banan is currently a sophomore in Electrical Engineering at the University of Washington.

Ms. Banan carries out various office management functions for Neda, including bookkeeping, accounts payable, data entry, and administrative support. She is also responsible for maintaining and updating Neda's technical and business documentation.

## **B Partners & Outside Support**

### **B.1 Van Valkenberg Furber Law Group P.L.L.C.**

Behind every good company is a good law firm. The Van Valkenberg Furber Law Group is Neda's principal legal services provider. The Van Valkenberg Furber Law Group is a specialized law firm formed to represent entrepreneurs in business transactions. Their core competencies consist of a set of structures for providing legal advice and assistance to evaluate alternative courses of action, implement an appropriate action plan, and complete corporate finance in accordance with criteria established by their client.

The Van Valkenberg Furber Law Group represents entrepreneurs and emerging growth companies at the stage of business development when they can add strategic value by combining their experience and expertise in their core competencies with a company's need to form business relationships in accessing investment capital, accelerating revenue growth, or executing a business combination. Their focus and their business model require that they select each client carefully. Because their fees are fixed, all of their clients represent investments. They contribute time, experience and political capital, so they choose to work with clients they believe are candidates for success, i.e. those who stand to benefit most from their advice and their relationships in the financial community.

### **B.2 Perkins Coie**

Perkins Coie is a major international law firm of 500 attorneys, serving clients from 14 offices in North America and Asia, including Anchorage, Bellevue, Boise, Denver, Los Angeles, Menlo Park, Olympia, Portland, San Francisco, Seattle, Spokane, Washington, D.C., Taipei and Hong Kong. The firm represents companies in nearly every type of business, from traditional enterprises such as manufacturing, aerospace, banking and real estate, to emerging fields such as electronic commerce, life sciences, technology and telecommunications. The firm's Washington office is known for its natural resource, antitrust, political law, government relations, technology and telecommunications, and international trade capabilities.

### **B.3 Public Relations Companies**

**pr.com** and **BlueSky** are two public relations companies with whom Neda has had recent discussions. Both of these companies have an understanding of Neda's public relations needs, have appropriate experience in the wireless field, and are interested in working with Neda. They are both candidates for our public relations firm.

### **B.4 Sun Micro Catalyst Program**

Neda has been a member of the Sun Micro Catalyst Program since 1991.

## C Neda Technology Balance Sheet

Over the past 8 years Neda has created a very large quantity of technological assets. These assets consist of items in the following categories:

- Protocol Specifications
  - ESRO Protocol (RFC 2188)
  - EMSD Protocol (RFC 2524)
  - EHTD Protocol (in progress)
- Publications
- Software
- Products
- Subscriber Services
- Networks and Domains
- Infrastructure, Tools and Procedures

In this appendix we provide a brief description of our assets in each of these categories. Pointers to additional information are provided where appropriate.

### C.1 Protocol Specifications

#### ESRO Protocol

- **RFC-2188:** Jointly with AT&T Wireless Services, Neda published Efficient Short Remote Operations (ESRO) as RFC-2188 [?].
- **ESRO.org:** Public enhancement and development of the ESRO protocol is supported by open maintenance organization ESRO.org at <http://www.esro.org>.

#### EMSD Protocol

- **RFC-2524:** The Efficient Mail Submission and Delivery (EMSD) protocol has been published as RFC-2524 [?].
- **EMSD.org:** Public enhancement and development of the EMSD protocol is supported by open maintenance organization EMSD.org at <http://www.emsd.org>.

### C.2 Publications

**Primary Architects of the CDPD Specifications:** Neda played a leadership role in the creation of the CDPD Specifications [?], [?].

**Internet E-Mail Services (Electronic Mail Association):** For the Electronic Mail Association (EMA), Neda developed a comprehensive report which described various aspects of Internet E-Mail Service [?].

**Internet Mobility Book (Prentice Hall):** Mohsen Banan is the co-author of *Internet Mobility: The CDPD Approach* [?]. This book includes a great deal of information which may be of interest to readers of this business plan who are unfamiliar with the wireless industry.

**Externally Defined E-Mail Body Parts (Electronic Mail Association):** For the Electronic Mail Association (EMA), Neda developed a comprehensive report which analyzed issues related to Externally Defined Body Parts [?] in electronic mail.

**Mobile-IP Survey:** As a public service to the Internet community and as a way of promoting our professional services, Neda has developed *The Mobile-IP Survey* [?]. This document maintains a list of existing implementations of Mobile-IP protocols.

**Introduction to Signaling System 7 (SS7):** As a public service to the Internet community and as a way of promoting our professional services, Neda has developed *Introduction to Signaling System 7 (SS7)* [?]. This document provides an overview of the Signaling System 7 network by providing a high-level description of existing standards, products and implementations.

### C.3 Neda Products

Over the past 5 years Neda has built a comprehensive and complete set of products which address all the basic areas of the LEAP-based Mobile Messaging industry.

These products address the basic needs of the following markets:

1. Protocol & Technology Market
2. Device Software Products Market
3. Message Center Software Products Market

#### C.3.1 Neda Product Summary

The following is a hierarchical summary of all of Neda's existing LEAP products:

- EMSD Device Software
  - ETWP-User-Agent Software (Device)
    - \* Windows CE
    - \* Windows 95, 98, NT
- EMSD Message Center Software and Systems
  - ISP ETWP-Server-Agent Software
    - \* Solaris (Sparc & X86)
  - Customer Premise ETWP-Server Agent Software
    - \* Solaris (Sparc & X86)
  - Personal ETWP-Server-Agent Software
    - \* Solaris (Sparc & X86)
- EMSD Protocol Engines Software

- EMSD Device Protocol Portable Source Code
- EMSD Server Protocol Portable Source Code
- EMSD Test Tools
- ESRO Protocol Engines Software
  - ESRO Protocol Portable Source Code
  - ESRO Test Tools
  - ESRO Development Toolkit - Binary License
    - \* Solaris (Sparc & X86)
    - \* Windows 95, 98 and NT

At this time the majority of these products are complete, tested, and adequately documented.

In the following sections we provide a description of each software product. For each product we provide the following information:

- The product name
- Current product status (alpha, beta or shipping)
- Supported platforms
- A reference to the relevant data sheet
- References to detailed product documentation (Product Manuals, User Guides, Installation Guides, Administration Guides, APIs, Application Notes)
- The target market served by the product
- A brief product description

### C.3.2 ETWP-User Agent Products

#### Windows CE ETWP-User-Agent Software

**Product Name:** ETWP-WCE: Enhanced Two-Way Paging for Windows CE Palmtop Computer

**Status:** Shipping

**Platforms:** Windows CE

**Data Sheets:** Data sheets available at reference [?].

**Documentation:** Additional information on this product is provided in the following documents:

- Efficient Mail Submission & Delivery (EMSD) on Windows CE [?]
- User Guide For ETWP Product [?]

**Target Markets:** This product is targeted for the End-User market and the Device Software market.

**Product Description:** Neda-ETWP is a complete implementation of the full Efficient Mail Submission & Delivery (EMSD) standard. On the Windows CE (WinCE) platform, this package is integrated directly into the standard Microsoft Windows CE “Inbox” e-mail application.

### **Win32 ETWP-User-Agent Software**

**Product Name:** ETWP-WIN: Enhanced Two-Way Paging for Windows 3.1-95 & NT

**Status:** Beta

**Platforms:** Windows 3.1 - 95 & Windows NT

**Data Sheets:** Data sheets available at reference [?].

**Documentation:** Additional information on this product is provided in the following documents:

- Pine-EMSD: User Guide and Source Modification [?]
- Efficient Mail Submission & Delivery (EMSD) on Windows CE [?]
- User Guide for ETWP Product [?]

**Target Markets:** This product is targeted for the End-User market and the Device Software market.

**Product Description:** Neda-ETWP is a complete implementation of the full Efficient Mail Submission & Delivery (EMSD) standard. By adding the popular e-mail interface (e.g. Pine from University of Washington) with Neda's submission & delivery protocol, EMSD Format Standard and Efficient Short Remote Operations (ESRO), ETWP is the perfect tool for desktops, laptops, or DOS/Windows-based handheld devices to send and receive EMSD messages.

### **C.3.3 ETWP-Server-Agent Products**

Our mobile messaging server agent products cover all types of deployment and usage. Neda has a separate product for each of the following markets:

- Public (ISP)
- Private (Corporate Intranet)
- Personal (Desktop)

Although all three of these products essentially use the same protocol engines, their overall packaging is very different.

#### **ISP ETWP-Server-Agent Software**

**Product Name:** ETWP - Server Agent: Enhanced Two-Way Paging for Solaris 2.x

**Status:** Beta

**Platforms:** Solaris (Sparc, X86)

**Data Sheets:** Data sheets available at reference [?].

**Documentation:** Additional information on this product is provided in the following documents:

- Neda Customer Premise Message Center (Neda-CPMC) Administrator's Guide [?]
- Neda MobileMsgWare Product Bundles for CDPD Network Operators [?]

**Target Markets:** This product is targeted for the Public Service Provider market.

**Product Description:** ETWP-Server Agent is a store and forward messaging center for mobile messaging over Wireless-IP and CDPD.

### **Customer Premise ETWP-Server-Agent Software**

**Product Name:** ETWP - Server Agent: Enhanced Two-Way Paging for Solaris 2.x

**Status:** Beta

**Platforms:** Solaris (Sparc, X86)

**Data Sheets:** Data sheets available at reference [?].

**Documentation:** Additional information on this product is provided in the following documents:

- Neda Customer Premise Message Center (Neda-CPMC) Administrator's Guide [?]
- Neda MobileMsgWare Product Bundles for CDPD Network Operators [?]

**Target Markets:** This product is targeted for the Message Center Software and Systems market.

**Product Description:** ETWP-Server Agent is a store and forward messaging center for mobile messaging over Wireless-IP and CDPD.

### **Personal ETWP-Server-Agent Software**

**Product Name:** ETWP - Server Agent: Enhanced Two-Way Paging for Solaris 2.x

**Status:** Beta

**Platforms:** Solaris (Sparc, X86)

**Data Sheets:** Data sheets available at reference [?].

**Documentation:** Additional information on this product is provided in the following document:

- Neda Customer Premise Message Center (Neda-CPMC) Administrator's Guide [?]

**Target Markets:** This product is targeted for the End User market.

**Product Description:** ETWP-Server Agent is a store and forward messaging center for mobile messaging over Wireless-IP and CDPD.

### **C.3.4 EMSD Protocol Technology Products**

Our EMSD protocol technology products are in the form of portable source code, and address the needs of Systems Integrators and message center developers.

#### **EMSD-P&FS-Device: Source**

**Product Name:** EMSD-P&FS-Device-Source: Efficient Mail Submission & Delivery Protocol & Format Standard

**Status:** Beta

**Platforms:** Solaris (Sparc, X86), DOS, Windows

**Data Sheets:** Data sheets available at reference [?].

**Documentation:** Additional information on this product is provided in the following documents:

- Neda's Implementation of EMSD-Server Agent: Source [?]
- Neda's Implementation of EMSD-User Agent: Source [?]
- Neda MobileMsgWare Product Bundles for Mobile Device Manufacturers [?]

**Target Markets:** This product is targeted for the Device Software market.

**Product Description:** EMSD-P&FS-Device: Source is portable source code for the EMSD client implementation, and is designed for wireless application developers and device and chip manufacturers for wireless devices.

#### **EMSD-P&FS-Server-Agent: Source**

**Product Name:** EMSD-P&FS-Server-Agent-Source: Efficient Mail Submission & Delivery Protocol & Format Standard

**Status:** Alpha

**Platforms:** Solaris (Sparc, X86), DOS, Windows

**Documentation:** Additional information on this product is provided in the following document:

- Neda's Implementation of EMSD-Server Agent: Source [?]

**Target Markets:** This product is targeted for the Device Software market.

**Product Description:** EMSD-P&FS-Server-Agent: Source is portable source code for the EMSD client implementation, and is designed for wireless application developers and device and chip manufacturers for wireless devices.

### **C.3.5 ESRO Protocol Technology Products**

Our ESRO protocol technology products are available in source code, and are targeted to the Device Manufacturer and System Integrator markets.

ESRO protocol technology can also be considered to be middleware for vertical applications of all kinds, such as Credit Card Verification, Telemetry, etc.

#### **ESRO Base - Source**

**Product Name:** ESRO: Base Source

**Status:** Beta

**Platforms:** Solaris (Sparc, X86), DOS, Windows

**Data Sheets:** Data sheets available at reference [?].

**Documentation:** Additional information on this product is provided in the following document:

- Neda's Implementation of ESRO: Source [?]

**Target Markets:** This product is targeted for the Device Software market.

**Product Description:** ESRO Base Source is portable source code for ESRO layer implementation. ESRO has been designed to meet the needs of wireless application developers, and device and chip manufacturers for wireless devices.



## **ESRO Test Tools - Source**

**Product Name:** ESRO: Test Tool Source

**Status:** Beta

**Platforms:** Solaris (Sparc, X86), DOS, Windows

**Data Sheets:** Data sheets available at reference [?].

**Documentation:** Additional information on this product is provided in the following document:

- Neda's Implementation of ESRO: Source [?]

**Target Markets:** This product is targeted for the Device Software market.

**Product Description:** ESRO Test Tools is a set of C programs, shell scripts, configuration files and related data files that include a scenario interpreter, a group of scenario files, an exception generator, and an exception generator scope program.

## **ESRO Toolkit - Binary**

**Product Name:** ESRO: Toolkit Binary

**Status:** Beta

**Platforms:** Solaris (Sparc, X86), DOS, Windows

**Documentation:** Additional information on this product is provided in the following document:

- ESRO Application Programming Interface [?]

**Target Markets:** This product is targeted for the Device Software market.

**Product Description:** ESRO has been designed to meet the needs of wireless application developers, and device and chip manufacturers for wireless devices.

## **C.4 Neda Subscriber Services**

Neda has created a set of Subscriber Services to support initial deployment of the LEAP protocols in end-user devices. These Subscriber Services are sufficient to support our Phase I operations, and will form the basis for our Phase II operations. They may also be used for demonstration purposes. In general, all Subscriber Services provided by Neda are available free to the user.

Neda's Subscriber Services accommodate various methods of accessing and using mobile messaging services. For this reason, they are distributed across multiple websites. See the following sites for complete details:

- ByName.net
- ByNumber.net

## **C.5 Networks and Domains**

Since 1991, we have had a class C address and a frame relay connection to the Internet. Since 1991 the aggregate network down time has been about 40 hours.

A large number of well-maintained independent domains and networks are maintained by Neda; these are summarized in Figure 13. Each domain serves a particular purpose towards the creation of the LEAP-based Mobile Messaging industry.

## **C.6 Infrastructure, Tools and Procedures**

Neda has been in business for ten years, and has developed a rich and mature set of internal operating tools and procedures.

We take pride in our disciplined and structured software development practices. We use a highly integrated set of tools that we consider to be the best in the industry.

## **D Recent Licensees**

The following is a summary of recent licensees of Neda software:

### **XYPOINT Corporation**

Product: Voice Response Development Environment (VoRDE)  
License: Full Commercial License and Software Maintenance Agreement  
Date : 1999

### **INETCO Systems**

Product: Efficient Short Remote Operations Protocol and Test Tools  
License: Full Commercial License and Software Maintenance Agreement  
Date : 1999

### **AT&T Wireless Services – Messaging Division**

Product: Enhanced Two-Way Paging Network Operators Toolkit  
for use over Narrow-Band PCS  
License: Full Commercial License and Software Maintenance Agreement  
Date : 1997

### **Sema Group UK**

Product: Efficient Short Remote Operations Protocol and Test Tools  
License: Source Code Commercial License and Software Maintenance Agreement  
Date : 1996

Web Site	Information Type	Description
<a href="http://www.EMSD.org">www.EMSD.org</a> <a href="http://www.ESRO.org">www.ESRO.org</a> <a href="http://www.LEAPForum.org">www.LEAPForum.org</a>	PROTOCOLS AND STANDARDS	<ul style="list-style-type: none"> <li>- Base Protocol Specifications</li> <li>- White Papers</li> <li>- Application Programming Interfaces</li> <li>- Supported Subnetworks and Devices</li> <li>- Related Mailing Lists</li> </ul>
<a href="http://www.FreeProtocols.org">www.FreeProtocols.org</a>	PATENT FREEDOM	<ul style="list-style-type: none"> <li>- Free Protocols Process &amp; Procedures</li> </ul>
<a href="http://www.NEDA.com">www.NEDA.com</a> <a href="http://www.MailMeAnywhere.org">www.MailMeAnywhere.org</a>	PRODUCTS	<ul style="list-style-type: none"> <li>- FREE Customer Products Windows CE Software for Enhanced Two-Way Paging</li> <li>- Message Center Products (Solaris)</li> <li>- Developer Toolkits</li> <li>- Service Bureau &amp; Intranet Products</li> </ul>
<a href="http://www.ByNumber.net">www.ByNumber.net</a> <a href="http://www.ByName.net">www.ByName.net</a>	SUBSCRIBER SERVICES	<ul style="list-style-type: none"> <li>- FREE Mobile Messaging Accounts</li> <li>- Web Based Message Origination</li> <li>- Interactive Voice Response Service for Enhanced Two-Way Paging</li> <li>- Advanced services for the sophisticated mobile professional</li> <li>- A coherent package addressing all of your personal communication needs in one place using "Your Name"</li> </ul>

Figure 13: Neda's Domains & Networks

## **Sierra Wireless**

Product: Enhanced Two-Way Paging For Windows CE  
License: Temporary Binary Evaluation License  
Date : 1998

## **BC Tel Mobility**

Product: Enhanced Two-Way Paging For Windows CE  
License: Temporary Binary Evaluation License  
Date : 1998

## **AT&T Wireless Services – Wireless Data Division (WDD)**

Product: Enhanced Two-Way Paging Network Operators Toolkit  
for use over CDPD  
License: Temporary Evaluation License  
Date : 1997

## **PCSI**

Product: ETWP-Customer Premise Message Center  
License: Temporary Binary License  
Date : 1996

## **E Recent Client List**

The following is a summary of recent consulting clients of Neda:

### **INETCO Systems**

Contract Period : 1999  
Services : Portation of ESRO Software Source package to Windows NT.

### **Sierra Wireless**

Contract Period : 1997 - 1998  
Services : Circuit Switched CDPD Protocol Software Portation  
Embedded Systems Software Design and Development

### **Geotek**

Contract Period : 1997 - 1998  
Services : Global Positioning System (GPS) Application Analysis

## **AT&T Wireless Data Division (WDD)**

Contract Period : 1992 - 1997

Services : CDPD Specification development,  
CDPD Network Deployment Planning,  
CDPD Applications Development

## **AT&T Messaging**

Contract Period : 1994 - 1997

Services : Narrow Band PCS and PACT protocol design and development,  
Two-Way Paging systems and device design and development

## **AT&T Corporate**

Contract Period : 1993 - 1995

Services : IS-41 Related Services

## **Data Critical**

Contract Period : 1995

Services : Wireless Data Applications Development

Contract Period : 1992 - 1993

Services : CDPD systems specification development

## **Electronic Mail Associations (EMA)**

Contract Period : 1992

Services : Internet E-Mail Technology Surveys

## **Emulex**

Contract Period : 1991 - 1993

Services : Data Communications Protocol Development

## **Motorola - WDG**

Contract Period : 1991

Services : Wireless Modem Software Portations

## **F Trying Out LEAP**

Everything that is necessary to allow anyone to try our current products and services and judge them independently are in place. For details, see the announcement entitled:

Announcing Free Availability Of  
Neda Communication Inc.'s  
Enhanced Two-Way Paging (ETWP) Product and Service  
For Windows CE Hand-held PCs  
Over CDPD and Wireless IP

Neda-ETWP-wce-gold-1.2

June 12, 1998

This announcement is available at [?].

The above mentioned announcement provides information about EVERYTHING that you need to turn your Windows CE device into a mobile messaging device, i.e.:

1. Buying a CDPD modem and getting a CDPD account from your cellular service provider.
2. Configuring your Windows CE Device to work with your CDPD modem.
3. Getting an Enhanced Two-Way Paging account from Neda.
4. Loading Neda's Enhanced Two-Way Paging product into your Windows CE Device.
5. Sending and Receiving Messages.